

DESIGN PACKAGE
for
HAMMIL VALLEY EMERGENCY SERVICES STATION

Mono County, California

Prepared for:
Mono County
Department of Public Works

June 30, 2011

FINAL



Prepared By:
HMR Architects, Inc.
2130 21st Street
Sacramento CA 95818



 HMRARCHITECTS

HAMMIL VALLEY EMERGENCY SERVICES STATION

Submitted to
Mono County
Department of Public Works

Contract No: B000113

June 30, 2011

HAMMIL VALLEY EMERGENCY SERVICES STATION

Table of Contents

- A. Project Scope
- B. Estimate of Probable Costs
- C. Outline Specification
 - Division 0 - Bidding and Contract Requirements (Not included)
 - Division 1 - General Requirements
 - Division 2 - Sitework
 - Division 3 - Concrete
 - Division 4 - Masonry
 - Division 5 - Metals
 - Division 6 - Wood and Plastic
 - Division 7 - Thermal and Moisture Control
 - Division 8 - Doors and Windows
 - Division 9 - Finishes
 - Division 10 - Specialties
 - Division 11 - Equipment
 - Division 12 - Furnishings
 - Division 13 - Special Construction
 - Division 14 - Conveying Systems
 - Division 15 - Mechanical
 - Division 16 - Electrical
- D. Site Photographs

HAMMIL VALLEY EMERGENCY SERVICES STATION

E. Drawings

AS-1	Site Plan
AS-1.1	Enlarged site plan
A-1.0	Apparatus Building Floor Plan
A-1.1	Apparatus Building Mezzanine Plan
A-1.2	Apparatus Building Elevations (East and South)
A-1.3	Apparatus Building Elevations (West and North)
A-1.4	Apparatus Building Section
A-2.0	Residence Building Floor Plan
A-2.1	Residence Building Elevations
A-2.2	Residence Building Section
A-3.0	Generator/Booster Pump/Well Building Floor Plan
A-3.1	Generator/Booster Pump/Well Building Elevations
A-3.2	Generator/Booster Pump/Well Building Section

Project Scope

A. Introduction

This project scope is for the construction of an emergency services station with a fire engine, water tender, ambulance and housing for medics. A helipad will also be onsite to provide helicopter transport. The project consists of three buildings, a two bedroom residence building to house medical personnel, 2-bay apparatus building (one bay is double stacked for fire equipment) and a generator/pump/well building. This project also includes a propane tank to service the buildings and generator, as well as a hose wash rack for maintaining equipment. The site is undeveloped. Site work includes clearing and grading for building pads, drainage and paving. The current site elevation is below the one hundred year flood level. According to information provided by the County, the finish floor elevation should be approximately at 4618.22 feet. That requires approximately four feet of fill material. The cost estimate includes a cost for fill over the area incorporating the three buildings, parking lot, adjoining driveways and the helipad. The driveway from the highway would have an approximate 2.5% slope up to the site. A new electrical service with transformer and switchgear will be tied to the existing three phase power provided in lines running along the east perimeter of the property adjacent to Highway 6. Two poles are within the parcel boundaries. Access to underground phone service is available at the same power poles. There is no municipal water or sewer service to the site. A well with a pump and storage tank will need to be installed for water service and a septic system installed for waste. This facility is to be fire sprinkled, requiring a fire service water storage tank with booster pump. The well, generator and booster pump will be housed in one building. Site work will also include walkways, irrigation, lighting, fencing, flag pole, trash enclosure and landscaping. Also a location has been designated for a future cellular tower. Construction may occur over multiple phases. The residence and apparatus buildings were designed such that they can be built separately in two phases. The floor plans can be modified to allow for a single building that attaches the residence and the apparatus building.

B. Project Description:

1. The project will be to design and construct a new emergency services station that houses both fire and medical apparatus. The facility will include single-story buildings that will include the following:
 - Apparatus Building
 - Residence Building
 - Generator/Pump/Well Building

2. Site Improvements will include:

- Grading and paving
- Utilities (electricity, phone, water, sewer)
- Hose wash rack 6'W x 55'L
- Flagpole
- Trash enclosure
- On site sidewalks
- Landscaping/irrigation
- Site lighting
- Storm Drainage Interceptor and Diversion
- Helipad
- Fencing –four strand barbed wire
- Encroachment work at main driveway
- Cattle gate
- Site Fire Loop, fire hydrants with separate Warf Hydrant at wash rack
- Propane Tank: 1,500 gallon
- Four feet of fill to raise buildings, parking lot, adjoining driveways and helipad above the 100 year flood level

Onsite there are three different paving types are being specified – concrete, asphalt and compacted aggregate base. Concrete is being shown for sidewalks adjacent to the buildings, at the trash enclosure, accessible parking stall/loading and the helipad. The accessible stall could also be in asphalt, however due to the way asphalt is installed and that it deteriorates faster than concrete, it is very difficult to achieve and maintain the code required slopes in the accessible parking stall and loading zone. Also it would be a very small island of asphalt on the site and more cost effective to install concrete while pouring the adjacent sidewalks. For these reasons it is being recommended that the accessible parking area be concrete instead of asphalt.

Concrete is also being shown for the helipad. Per the U.S. Department of Transportation Federal Aviation Administration Advisory Circular AC150/5390-2B Portland Cement Concrete is recommended for all heliport surfaces used by helicopters. Concrete is a better suited material to support loads imposed by a helicopter and vehicles; combat erosive effects of rotor wash; and facilitate surface runoff. The minimum concrete depth recommended is six (6) inches which is capable of supporting helicopters up to 20,000 pounds. Thicker pavement would be required for heavier loads, but the anticipated use of this facility would not necessitate the use of helicopters above that weight. Also ground lighting is required for the helipad that would be better supported in concrete and difficult to install in asphalt.

Asphalt is being shown in the drive areas adjacent to the apparatus building, helipad and driveway entrance at Highway 6 as well as at the hose wash area. The remainder of the paved areas would be compacted aggregate base.

3. Energy and Sustainability:

- The County is considering adopting sustainability requirements. The buildings can be designed to meet the US Green Building Council's Leadership in Energy and Environmental Design (LEED) requirements to attain a Silver rating.

4. Plumbing Systems - General:

- Domestic water will be well water.
- The waste system will be a septic system and leach field.
- Storm water systems will connect to an on-site interceptor and drain to off site storm culvert
- Propane gas will be used for heating.
- Condensate drains from the air-conditioning unit cooling coils will be piped to the waste or storm system.
- Any plumbing systems exposed to freezing conditions will be provided with heat trace freeze protection.
- Plumbing fixtures will be porcelain enamel except kitchen sink which shall be stainless steel.

5. Fire Protection - General:

- A hydraulically calculated full dry pipe automatic fire sprinkler system is proposed for all buildings and any overheads and combustible blind spaces. Flow switches and tamper switches shall be monitored by the fire alarm system. Fire protection piping in locations exposed to freezing conditioning will be provided with heat trace.
- A fire department connection will be provided, for system pressurization by the fire department pumper trucks, within forty (40) feet of the building, in a location to be approved by the Fire Department. The fire sprinkler system will be connected to the water main with an approved double check backflow valve and post indicator valve.

6. Building Occupancies and Construction Types:

The edition of the California Building Code that is in effect at the time the design work commences shall be referenced during the course of this work.

	Building Type:	Occupancy:	Const. Type:
1.	Residence	R-3	V-B, sprinkled
2.	Apparatus Building	U and B	V-B, sprinkled
3.	Generator/Pump/Well Building :	U	V-B, not sprinkled

7. Building Construction Elements:

A. All buildings (unless otherwise noted):

1. Prepare building pad to 5'-0" beyond the building line with all utilities.
2. Place a 5" reinforced concrete slab on grade foundation over a sand base over vapor barrier over a crushed rock base.
3. Standing seam metal roofing with concealed fasteners
4. Vinyl frame windows typical.
5. Metal exterior and interior door frames
6. Insulated exterior metal doors.
7. Insulated interior wood doors.
8. All buildings to be fire sprinkled with commercial standard type sprinklers except the Generator/Pump/Well Building.
9. Lighting: All exterior fixtures to be compact fluorescent or metal halide. All interior light fixtures to be standard 4 foot fluorescent with electronic ballasts and T8 lamps or recessed compact fluorescent fixtures.
10. Metal 'leafless' gutters and downspouts
11. Exterior wall pack building lighting
12. Exterior speaker system
13. Security/Fire Alarm System

B. Residence Building:

1. General:
 - a. Painted interior gypsum board wall and ceiling surfaces
 - b. All rooms to have speakers with volume control
 - c. Satellite TV/Internet system
 - d. Recessed compact fluorescent lighting
 - e. Stainless steel accessible dual sink at kitchen
 - f. Four burner electric range at kitchen
 - g. Ceiling fans in every room with dual switches

2. Flooring:
 - a. Sheet Vinyl: Kitchen/Dining Area, laundry room (w/ coved base)
 - b. Carpet: Bedrooms, living area
 - c. Exposed Concrete with sealer: Mechanical/Electrical Room floor
 - d. Ceramic Tile: Bathrooms
 - e. Rubber base: All carpet and VCT areas.
3. Furnishings: Hardwood Oak casework.
 - a. Solid surface countertops/backsplash at bathrooms and kitchen
 - b. Oak upper and base cabinets at kitchen
4. Structural System: 2x6 wood structural bearing walls on spread concrete foundation. Pre-engineered wood trusses with center web section open for mechanical systems.
5. Mechanical systems: Split package units with outdoor condenser unit. Supply and Return air in each room
6. Electrical systems: 200A, 120/208 3-Phase 4 wire underground feeder from 800A electrical service
7. Minimum R-30 roof insulation
8. Minimum R-19 wall insulation
9. Exterior:
 - a. Cement Board panel siding
 - b. Overhang at entrance
 - c. Standard sliding windows

D. Apparatus Building:

1. General:
 - a. Place a reinforced 8" concrete slab on grade foundation over a sand base over vapor barrier over a crushed rock base with 8" concrete slab at vehicle aprons
 - b. Carbon Monoxide sensor
 - c. Floor Drains
 - d. Ventilation System
 - e. Overhead coiling doors to be insulated with vision panels, sized 12'-0" wide by 14'-0" tall at the ambulance bay and 14'-0" wide by 14'-0" high for the fire apparatus.
 - f. Plastic laminate upper and base cabinets at work area with plywood countertop and utility sink.
 - g. Mezzanine with wood floor joists, plywood decking and metal railings.
 - h. Painted interior gypsum board wall and ceiling surfaces at office and restroom

- i. Occupancy sensors for lighting fixtures
- j. Satellite TV/Internet system
- 2. Structural system: Steel columns and beams with steel purlins
- 3. Mechanical System:
 - a. Gas fired Unit Heaters and Evaporative Cooler at Apparatus. Bay
 - b. Thru wall AC unit at office
- 4. Electrical systems: 400A, 120/208 3-Phase 4-Wire underground feeder from 800A electrical service.
- 5. Minimum R-30 roof insulation
- 6. Minimum R-19 wall insulation
- 7. Exterior:
 - a. Insulated metal panels
 - b. Standard sliding windows

F. Generator/Pump/Well Building:

- 1. Structural System: Splitface concrete masonry units (CMU) block construction Metal roof over 5/8" plywood over pre-manufactured roof trusses.
- 2. Mechanical systems: Exhaust fan and discharge louver
- 3. Flooring: Exposed concrete with sealer
- 4. Main Electrical Service: 800A, 120/208 3-Phase 4-Wire service switchboard
- 5. Generators: 1 80KW dual fuel emergency generator
- 6. Building Electrical system: 200A, 120/208 3-Phase 4 wire underground feeder from 800A electrical service.

SILVA COST CONSULTING, INC.

1812 J Street, Suite 5
Sacramento, CA 95811

P: 916.444.1130
F: 916.444.1131

Hammil Valley Emergency Services Station

Budget Package Cost Estimate

June 30, 2011

Prepared for:
HMR Architects
2130 21ST Street
Sacramento, CA 95818

SILVA COST CONSULTING, INC.

1812 J Street, Suite 5
Sacramento, CA 95811

P: 916.444.1130
F: 916.444.1131

June 30, 2011

Kim Demongey
HMR Architects
2130 21st Street
Sacramento, CA 95818

Reference: **Hammil Valley Emergency Services Station**

Subject: **Budget Package Cost Estimate**

Dear Kim,

Thank you for the opportunity to provide you with this Cost Estimate for the above referenced project. The estimate is broken up into several sections as follows:

The Narrative portion which lists:

- The information used in preparing the estimate
- The estimate qualifications and assumptions
- The exclusions to the estimate
- The preface to the estimate which outlines our methodology

The Estimate portion, which contains:

- The Project Summary (which summarizes the estimate items in the estimate)
 - The Estimate Summary (which summarizes the CSI divisions for each item in the estimate)
 - The Estimate Detail (which lists the line items and unit prices by CSI for the estimate)

Once again I would like to thank you for this opportunity to offer my services. Please review the attached estimate and comment. Feel free to call me at 916-444-1130 should you have any questions, comments or concerns. Thank you.

Sincerely,
SILVA COST CONSULTING, INC.

Javier Silva
Principal

ITEMS USED IN PREPARING THE ESTIMATE

Specifications:	Outline specification as prepared by HMR Architects	4/14/11
Reports:	Budget package report prepared by HMR Architects	4/14/11
Civil Drawings:	None	
Landscape Drawings:	None	
Architectural Drawings:	AS-1.0, AS-1.1, AS-1.0, A-1.0, A-1.1, A-1.2, A-1.3, A-1.4, A-2.0, A-2.1, A-2.2, A-3.0, A-3.1, A-3.2 prepared by HMR Architects	4/14/11
Structural Drawings:	None	
Mechanical Drawings:	None	
Plumbing Drawings:	None	
Electrical Drawings:	None	
Other:	None	

ESTIMATE QUALIFICATIONS

- The project is located in Mono County CA.
- The estimate was priced using prevailing wage rates.
- We assume the project will be competitively bid.
- Start date of construction is unknown at this time.
- Construction duration is unknown at this time.
- The project will be done in one continuous phase.
- Work areas are to be unoccupied during construction.
- Work hours assumed, are 8 hours per day, 40 hours per week. Premiums for overtime or weekend work are not included in this estimate.
- We include a design contingency of 15%.
- The estimate is escalated 1%.

ITEMS SPECIFICALLY EXCLUDED FROM THE ESTIMATE

- Fees for architectural, structural, civil, mechanical, electrical, or other design fees.
- Permit fees, or inspection fees.
- Utility hook up fees.
- Premiums for overtime work.
- Division 13: Special Construction.
- Division 14: Conveying.
- Items not specifically shown in estimate.

PREFACE TO ESTIMATE

The estimate hereunder has been compiled from drawings and specifications (if available) believed to be an accurate portrayal of the project as drawn and indicated by the architect and/or engineers. If said drawings and specifications are incomplete, the project cost engineer has included those items as would usually appear in final drawings and specifications for a complete project in a manner ordinarily prudent under the circumstances. Specialty items unknown to the cost engineer will not normally be included unless communicated through the architect and/or engineer.

The user is cautioned that changes in the scope of the project or the drawings and specifications after the estimate has been submitted can cause cost changes and the cost engineer should be notified for appropriate addenda to be issued to the estimate.

The estimate has also been adjusted for geographical location based on local material and labor rates as well as local construction practice.

This estimate is based on a competitive bid situation, involving 4 or more bidders with 4 sub bids per trade.

PROJECT SUMMARY

PROJECT:	Hammil Valley Emergency Services Station	DATE:	6/30/2011
DESIGN LVL:	Budget Package	ESTIMATOR:	Javier Silva
CLIENT:	HMR Architects	SCHEDULE:	

ITEM NO.	ITEM DESCRIPTION	AREA (SF)	PROJECT COST	\$/SF
1	SITework - PHASE 1	118,933	909,155	7.64
2	PUMP/WELL/GENERATOR BUILDING - PHASE 2	622	124,452	200.08
3	APPARATUS BUILDING - PHASE 3	3,035	699,191	230.39
4	HELIPAD - PHASE 4	3,850	92,913	24.13
5	RESIDENCE BUILDING - PHASE 5	1,125	344,874	306.55
	TOTAL CONSTRUCTION COST:	8,010	2,170,585	270.99

ALT. NO.	ALTERNATE DESCRIPTION	AREA (SF)	PROJECT COST	\$/SF
1	ALTERNATE 1			
2	ALTERNATE 2			
3	ALTERNATE 3			

ESTIMATE SUMMARY

Project:	Hammit Valley Emergency Services Station	Date:	6/30/2011
Level:	Budget Package	Estimator:	Javier Silva
Client:	HMR Architects	Schedule:	0
Location:	Sitework - Phase 1	Area (SF):	118,933

ITEM	DESCRIPTION	UNIT COST	TOTAL AMOUNT
------	-------------	-----------	--------------

1.0	GENERAL CONDITIONS	\$/SF:	0.10	12,000
2.1	SITE DEMOLITION	\$/SF:	0.08	10,000
2.2	EARTHWORK AND GRADING	\$/SF:	0.50	60,000
2.3	STORM DRAINAGE	\$/SF:	0.21	25,000
2.4	WATER DISTRIBUTION	\$/SF:	1.11	131,500
2.5	SANITARY SEWERAGE	\$/SF:	0.08	10,000
2.6	AC PAVING AND PARKING	\$/SF:	0.32	38,200
2.7	SITE CONCRETE	\$/SF:	0.17	19,630
2.8	SITE METALS	\$/SF:	0.04	5,000
2.9	LANDSCAPING AND IRRIGATION	\$/SF:	0.15	17,500
2.10	FENCES AND GATES	\$/SF:	0.11	13,500
2.11	SITE EQUIPMENT	\$/SF:	0.14	16,500
2.12	SITE FURNISHINGS	\$/SF:	0.13	16,000
2.13	SITE STRUCTURES	\$/SF:	0.09	10,123
15.0	SITE PLUMBING	\$/SF:	0.94	112,000
16.0	SITE ELECTRICAL	\$/SF:	1.57	187,000

SUBTOTAL		683,952
GENERAL CONDITIONS	10.00%	68,395
BONDS & INSURANCE	2.00%	15,047
OVERHEAD & PROFIT	2.00%	15,348
DESIGN CONTINGENCY	15.00%	117,411
ESCALATION	1.00%	9,002
TOTAL CONSTRUCTION COST		909,155
	TOTAL \$/SF:	7.64

ESTIMATE DETAIL

Project:	Hammil Valley Emergency Services Station	Date:	6/30/2011
Level:	Budget Package	Estimator:	Javier Silva
Client:	HMR Architects	Schedule:	
Location:	Sitework - Phase 1	Area (SF):	118,933

ITEM	DESCRIPTION	QUANTITY	UNIT	UNIT COST	TOTAL AMOUNT
------	-------------	----------	------	-----------	--------------

1.0	GENERAL CONDITIONS				
	Erosion control	1	ls	12,000.00	12,000
	Subtotal General Conditions		\$/SF:	0.10	12,000

2.1	SITE DEMOLITION				
	Clearing and grubbing, minor site demo	118,933	sf	0.08	10,000
	Subtotal Site Demolition		\$/SF:	0.08	10,000

2.2	EARTHWORK AND GRADING				
	General site grading	118,933	sf	0.29	35,000
	Fill generated on site	7,100	cy	3.52	25,000
	Subtotal Earthwork And Grading		\$/SF:	0.50	60,000

2.3	STORM DRAINAGE				
	Storm drainage allowance	118,933	sf	0.21	25,000
	Subtotal Storm Drainage		\$/SF:	0.21	25,000

2.4	WATER DISTRIBUTION				
	New domestic water well	1	ea	30,000.00	30,000
	Domestic water distribution allowance	145	sf	84.83	12,300
	Fire hydrants	1	ea	3,000.00	3,000
	Fire hydrant piping, 6"	205	lf	60.00	12,300
	Fire sprinkler water	65	lf	60.00	3,900
	Fire water booster pump	1	ea	60,000.00	60,000
	FDC/PIV/DCVBFP assembly	1	ea	10,000.00	10,000
	Subtotal Water Distribution		\$/SF:	1.11	131,500

ESTIMATE DETAIL

Project:	Hammil Valley Emergency Services Station	Date:	6/30/2011
Level:	Budget Package	Estimator:	Javier Silva
Client:	HMR Architects	Schedule:	
Location:	Sitework - Phase 1	Area (SF):	118,933

ITEM	DESCRIPTION	QUANTITY	UNIT	UNIT COST	TOTAL AMOUNT
------	-------------	----------	------	-----------	--------------

2.5	SANITARY SEWERAGE				
	Septic system incl. leach field and tanks	700	gpd	14.29	10,000
	Subtotal Sanitary Sewerage		\$/SF:	0.08	10,000

2.6	AC PAVING AND PARKING				
	AC paving, assume 3/8	9,300	sf	3.50	32,550
	Compacted aggregate base	16,500	sf	0.30	4,950
	HC parking stall with sign and wheel stop	1	ea	700.00	700
	Subtotal Ac Paving And Parking		\$/SF:	0.32	38,200

2.7	SITE CONCRETE				
	Concrete paving, 4", bar reinforced	2,650	sf	7.41	19,630
	Subtotal Site Concrete		\$/SF:	0.17	19,630

2.8	SITE METALS				
	Site bollards and other misc. metals	1	ls	5,000.00	5,000
	Subtotal Site Metals		\$/SF:	0.04	5,000

2.9	LANDSCAPING AND IRRIGATION				
	Landscaping and irrigation	3,500	sf	5.00	17,500
	Subtotal Landscaping And Irrigation		\$/SF:	0.15	17,500

2.10	FENCES AND GATES				
	4 strand barbed wire fence, metal posts	1,150	lf	10.00	11,500
	Cattle gate	1	ea	2,000.00	2,000

ESTIMATE DETAIL

Project:	Hammil Valley Emergency Services Station	Date:	6/30/2011
Level:	Budget Package	Estimator:	Javier Silva
Client:	HMR Architects	Schedule:	
Location:	Sitework - Phase 1	Area (SF):	118,933

ITEM	DESCRIPTION	QUANTITY	UNIT	UNIT COST	TOTAL AMOUNT
------	-------------	----------	------	-----------	--------------

	Subtotal Fences And Gates		\$/SF:	0.11	13,500
--	----------------------------------	--	--------	------	---------------

2.11	SITE EQUIPMENT				
	Hose wash rack	1	ea	16,500.00	16,500
	Subtotal Site Equipment		\$/SF:	0.14	16,500

2.12	SITE FURNISHINGS				
	Concrete monument sign	1	ea	10,000.00	10,000
	Flag pole	2	ea	3,000.00	6,000
	Subtotal Site Furnishings		\$/SF:	0.13	16,000

2.13	SITE STRUCTURES				
	Trash Enclosure				
	6" pad and apron	312	sf	11.11	3,467
	CMU walls	216	sf	16.00	3,456
	Footings	5	cy	600.00	3,200
	Subtotal Site Structures		\$/SF:	0.09	10,123

15.0	SITE MECHANICAL				
	1,500 gallon propane tank, for generator	1	ea	30,000.00	30,000
	60,000 gallon fire storage tank, 8'0" high, pumps, etc.	1	ea	70,000.00	70,000
	Underground distribution system for propane	200	lf	20.00	4,000
	Domestic water submersible well pump	1	ea	8,000.00	8,000
	Subtotal Site Mechanical		\$/SF:	0.94	112,000

16.0	SITE ELECTRICAL				
	Transformer	1	ea	50,000.00	50,000

ESTIMATE DETAIL

Project:	Hammil Valley Emergency Services Station	Date:	6/30/2011
Level:	Budget Package	Estimator:	Javier Silva
Client:	HMR Architects	Schedule:	
Location:	Sitework - Phase 1	Area (SF):	118,933

ITEM	DESCRIPTION	QUANTITY	UNIT	UNIT COST	TOTAL AMOUNT
	Feeder from pole to transformer	35	lf	200.00	7,000
	Feeder from transformer to MSB	250	lf	200.00	50,000
	Feeder from MSB to buildings	250	lf	100.00	25,000
	MSB, 800A, in pump building	1	ea	20,000.00	20,000
	Site telecom	250	lf	100.00	25,000
	Site lighting	1	ls	10,000.00	10,000
	Subtotal Site Electrical		\$/SF:	1.57	187,000

ESTIMATE SUMMARY

Project:	Hammit Valley Emergency Services Station	Date:	6/30/2011
Level:	Budget Package	Estimator:	Javier Silva
Client:	HMR Architects	Schedule:	0
Location:	Pump/Well/Generator Building - Phase 2	Area (SF):	622

ITEM	DESCRIPTION	UNIT COST	TOTAL AMOUNT
------	-------------	-----------	--------------

2.0	DEMOLITION	\$/SF:	-	-
3.0	CONCRETE	\$/SF:	19.30	12,005
4.0	MASONRY	\$/SF:	36.36	22,614
5.0	METALS	\$/SF:	-	-
6.R	ROUGH CARPENTRY	\$/SF:	14.63	9,101
6.F	FINISH CARPENTRY	\$/SF:	-	-
7.0	THERMAL & MOISTURE PROTECTION	\$/SF:	23.61	14,687
8.0	DOORS & WINDOWS	\$/SF:	18.33	11,400
9.0	FINISHES	\$/SF:	-	-
10.0	SPECIALTIES	\$/SF:	-	-
11.0	EQUIPMENT	\$/SF:	-	-
12.0	FURNISHINGS	\$/SF:	-	-
13.0	SPECIAL CONSTRUCTION	\$/SF:	-	-
14.0	CONVEYING	\$/SF:	-	-
15.F	FIRE PROTECTION	\$/SF:	-	-
15.M	MECHANICAL	\$/SF:	9.65	6,000
15.P	PLUMBING	\$/SF:	1.61	1,000
16.0	ELECTRICAL	\$/SF:	27.04	16,818

SUBTOTAL		93,624
GENERAL CONDITIONS	10.00%	9,362
BONDS & INSURANCE	2.00%	2,060
OVERHEAD & PROFIT	2.00%	2,101
DESIGN CONTINGENCY	15.00%	16,072
ESCALATION	1.00%	1,232
TOTAL CONSTRUCTION COST		124,452
	TOTAL \$/SF:	200.08

ESTIMATE DETAIL

Project:	Hammil Valley Emergency Services Station	Date:	6/30/2011
Level:	Budget Package	Estimator:	Javier Silva
Client:	HMR Architects	Schedule:	
Location:	Pump/Well/Generator Building - Phase 2	Area (SF):	622

ITEM	DESCRIPTION	QUANTITY	UNIT	UNIT COST	TOTAL AMOUNT
------	-------------	----------	------	-----------	--------------

2.0	DEMOLITION				
	None				
	Subtotal Demolition		\$/SF:		

3.0	CONCRETE				
	5" slab on grade, reinforcing, vapor barrier, rock and sand	622	sf	9.30	5,785
	Footings and grade beams, incl. excavation/reinforcing, etc.	622	sf	10.00	6,220
	Subtotal Concrete		\$/SF:	19.30	12,005

4.0	MASONRY				
	8" CMU walls	1,413	sf	16.00	22,614
	Subtotal Masonry		\$/SF:	36.36	22,614

5.0	METALS				
	None				
	Subtotal Metals		\$/SF:		

6.R	ROUGH CARPENTRY				
	Roof truss framing with plywood sheathing	910	sf	10.00	9,101
	Subtotal Rough Carpentry		\$/SF:	14.63	9,101

6.F	FINISH CARPENTRY				
	None				

ESTIMATE DETAIL

Project:	Hammil Valley Emergency Services Station	Date:	6/30/2011
Level:	Budget Package	Estimator:	Javier Silva
Client:	HMR Architects	Schedule:	
Location:	Pump/Well/Generator Building - Phase 2	Area (SF):	622

ITEM	DESCRIPTION	QUANTITY	UNIT	UNIT COST	TOTAL AMOUNT
------	-------------	----------	------	-----------	--------------

	Subtotal Finish Carpentry		\$/SF:		
--	----------------------------------	--	--------	--	--

7.0	THERMAL & MOISTURE PROTECTION				
	Standing seam metal roofing	910	sf	15.00	13,651
	Gutters/downspouts	88	lf	10.00	880
	Sealants and caulking	622	sf	0.25	156
	Subtotal Thermal & Moisture Protection		\$/SF:	23.61	14,687

8.0	DOORS & WINDOWS				
	Exterior hm doors, frames and hardware	4	ea	1,500.00	6,000
	Louvers	72	sf	75.00	5,400
	Subtotal Doors & Windows		\$/SF:	18.33	11,400

9.0	FINISHES				
	None				
	Subtotal Finishes		\$/SF:		

10.0	SPECIALTIES				
	None				
	Subtotal Specialties		\$/SF:		

11.0	EQUIPMENT				
	None				
	Subtotal Equipment		\$/SF:		

12.0	FURNISHINGS				

ESTIMATE DETAIL

Project:	Hammil Valley Emergency Services Station	Date:	6/30/2011
Level:	Budget Package	Estimator:	Javier Silva
Client:	HMR Architects	Schedule:	
Location:	Pump/Well/Generator Building - Phase 2	Area (SF):	622

ITEM	DESCRIPTION	QUANTITY	UNIT	UNIT COST	TOTAL AMOUNT
------	-------------	----------	------	-----------	--------------

	None				
	Subtotal Furnishings		\$/SF:		

13.0	SPECIAL CONSTRUCTION				
	None				
	Subtotal Special Construction		\$/SF:		

14.0	CONVEYING				
	None				
	Subtotal Conveying		\$/SF:		

15.F	FIRE PROTECTION				
	None				
	Subtotal Fire Protection		\$/SF:		

15.M	MECHANICAL				
	Exhaust fans	3	ea	2,000.00	6,000
	Subtotal Mechanical		\$/SF:	9.65	6,000

15.P	PLUMBING				
	Plumbing, per fixture	1	ea	1,000.00	1,000
	Subtotal Plumbing		\$/SF:	1.61	1,000

16.0	ELECTRICAL				
	Equipment, switchgear, panelboards, etc.	622	sf	8.04	5,000

ESTIMATE DETAIL

Project:	Hammil Valley Emergency Services Station	Date:	6/30/2011
Level:	Budget Package	Estimator:	Javier Silva
Client:	HMR Architects	Schedule:	
Location:	Pump/Well/Generator Building - Phase 2	Area (SF):	622

ITEM	DESCRIPTION	QUANTITY	UNIT	UNIT COST	TOTAL AMOUNT
	Power, convenience, hvac, etc.	622	sf	5.00	3,110
	Lighting and controls	622	sf	8.00	4,976
	Fire alarm	622	sf	3.00	1,866
	Telecom	622	sf	3.00	1,866
	Subtotal Electrical		\$/SF:	27.04	16,818

ESTIMATE SUMMARY

Project:	Hammit Valley Emergency Services Station	Date:	6/30/2011
Level:	Budget Package	Estimator:	Javier Silva
Client:	HMR Architects	Schedule:	0
Location:	Apparatus Building - Phase 3	Area (SF):	3,035

ITEM	DESCRIPTION	UNIT COST	TOTAL AMOUNT
------	-------------	-----------	--------------

2.0	DEMOLITION	\$/SF:	-	-
3.0	CONCRETE	\$/SF:	21.87	66,362
4.0	MASONRY	\$/SF:	-	-
5.0	METALS	\$/SF:	33.27	100,958
6.R	ROUGH CARPENTRY	\$/SF:	12.41	37,663
6.F	FINISH CARPENTRY	\$/SF:	2.80	8,500
7.0	THERMAL & MOISTURE PROTECTION	\$/SF:	2.48	7,515
8.0	DOORS & WINDOWS	\$/SF:	15.03	45,625
9.0	FINISHES	\$/SF:	36.02	109,311
10.0	SPECIALTIES	\$/SF:	2.87	8,700
11.0	EQUIPMENT	\$/SF:	-	-
12.0	FURNISHINGS	\$/SF:	0.08	250
13.0	SPECIAL CONSTRUCTION	\$/SF:	-	-
14.0	CONVEYING	\$/SF:	-	-
15.F	FIRE PROTECTION	\$/SF:	6.00	18,209
15.M	MECHANICAL	\$/SF:	6.26	19,000
15.P	PLUMBING	\$/SF:	8.24	25,000
16.0	ELECTRICAL	\$/SF:	26.00	78,904

SUBTOTAL		525,997
GENERAL CONDITIONS	10.00%	52,600
BONDS & INSURANCE	2.00%	11,572
OVERHEAD & PROFIT	2.00%	11,803
DESIGN CONTINGENCY	15.00%	90,296
ESCALATION	1.00%	6,923
TOTAL CONSTRUCTION COST		699,191
	TOTAL \$/SF:	230.39

ESTIMATE DETAIL

Project:	Hammil Valley Emergency Services Station	Date:	6/30/2011
Level:	Budget Package	Estimator:	Javier Silva
Client:	HMR Architects	Schedule:	
Location:	Apparatus Building - Phase 3	Area (SF):	3,035

ITEM	DESCRIPTION	QUANTITY	UNIT	UNIT COST	TOTAL AMOUNT
------	-------------	----------	------	-----------	--------------

2.0	DEMOLITION				
	None				
	Subtotal Demolition		\$/SF:		

3.0	CONCRETE				
	8" slab on grade, reinforcing, vapor barrier, rock and sand	2,400	sf	14.85	35,640
	Footings and grade beams, incl. excavation/reinforcing, etc.	2,400	sf	10.00	24,000
	6" curb around perimeter of building	149	lf	20.00	2,980
	Concrete aprons, 8" thick, bar reinforced, at roll up door exits	252	sf	14.85	3,742
	Subtotal Concrete		\$/SF:	21.87	66,362

4.0	MASONRY				
	None				
	Subtotal Masonry		\$/SF:		

5.0	METALS				
	Structural steel, 10 lbs per sf	30,348	lbs	2.50	75,870
	Metal roof deck	2,968	sf	3.50	10,388
	Bollards	6	ea	500.00	3,000
	Metal guardrail with 6'0" wide swing section	39	lf	300.00	11,700
	Subtotal Metals		\$/SF:	33.27	100,958

6.R	ROUGH CARPENTRY				
	Interior wall framing	593	sf	7.60	4,508
	Mezzanine floor framing with 3/4" plywood sheathing	635	sf	20.45	12,981

ESTIMATE DETAIL

Project:	Hammil Valley Emergency Services Station	Date:	6/30/2011
Level:	Budget Package	Estimator:	Javier Silva
Client:	HMR Architects	Schedule:	
Location:	Apparatus Building - Phase 3	Area (SF):	3,035

ITEM	DESCRIPTION	QUANTITY	UNIT	UNIT COST	TOTAL AMOUNT
	Post and beam allowance	3,035	sf	5.00	15,174
	Stairs and railings	1	ea	5,000.00	5,000
	Subtotal Rough Carpentry		\$/SF:	12.41	37,663

6.F	FINISH CARPENTRY				
	Work area base cabinets	15	lf	300.00	4,500
	Work area upper cabinets	20	lf	200.00	4,000
	Subtotal Finish Carpentry		\$/SF:	2.80	8,500

7.0	THERMAL & MOISTURE PROTECTION				
	Underfloor insulation	211	sf	1.50	317
	Roof insulation	2,400	sf	2.00	4,800
	Gutters/downspouts	164	lf	10.00	1,640
	Sealants and caulking	3,035	sf	0.25	759
	Subtotal Thermal & Moisture Protection		\$/SF:	2.48	7,515

8.0	DOORS & WINDOWS				
	14'x14' roll up door	2	ea	9,800.00	19,600
	12'x14' roll up door	1	ea	8,400.00	8,400
	Exterior hm doors, frames and hardware	3	ea	2,000.00	6,000
	Interior wd doors, frames and hardware	2	ea	1,500.00	3,000
	Exterior windows	115	sf	75.00	8,625
	Subtotal Doors & Windows		\$/SF:	15.03	45,625

9.0	FINISHES				
	Exterior Finishes				
	Insulated metal panels, with sub framing	4,619	sf	20.00	92,380
	Drywall Assemblies				
	Drywall to wall framing	1,186	sf	2.25	2,669

ESTIMATE DETAIL

Project:	Hammil Valley Emergency Services Station	Date:	6/30/2011
Level:	Budget Package	Estimator:	Javier Silva
Client:	HMR Architects	Schedule:	
Location:	Apparatus Building - Phase 3	Area (SF):	3,035

ITEM	DESCRIPTION	QUANTITY	UNIT	UNIT COST	TOTAL AMOUNT
------	-------------	----------	------	-----------	--------------

	Floor Finishes				
	Sealed concrete	2,254	sf	1.00	2,254
	VCT in office	146	sf	4.00	585
	Rubber base	49	lf	3.00	147
	Ceiling Finishes				
	Open ceiling, paint	2,400	sf	1.50	3,600
	Painted drywall ceilings	514	sf	10.00	5,139
	Acoustic ceiling in office	146	sf	4.00	585
	Wall Finishes				
	Paint drywall	1,186	sf	1.00	1,186
	FRP wainscot	128	sf	6.00	768
	Subtotal Finishes		\$/SF:	36.02	109,311

10.0	SPECIALTIES				
	Restroom accessories	1	lot	1,500.00	1,500
	Lockers, 2-tier	18	ea	400.00	7,200
	Subtotal Specialties		\$/SF:	2.87	8,700

11.0	EQUIPMENT				
	Not used				
	Subtotal Equipment		\$/SF:		

12.0	FURNISHINGS				
	Window blinds in office	1	ea	250.00	250
	Subtotal Furnishings		\$/SF:	0.08	250

13.0	SPECIAL CONSTRUCTION				

ESTIMATE DETAIL

Project:	Hammil Valley Emergency Services Station	Date:	6/30/2011
Level:	Budget Package	Estimator:	Javier Silva
Client:	HMR Architects	Schedule:	
Location:	Apparatus Building - Phase 3	Area (SF):	3,035

ITEM	DESCRIPTION	QUANTITY	UNIT	UNIT COST	TOTAL AMOUNT
	None				
	Subtotal Special Construction		\$/SF:		

14.0	CONVEYING				
	None				
	Subtotal Conveying		\$/SF:		

15.F	FIRE PROTECTION				
	Wet pipe fire sprinkler system	3,035	sf	6.00	18,209
	Subtotal Fire Protection		\$/SF:	6.00	18,209

15.M	MECHANICAL				
	Radiant heaters	3	ea	5,000.00	15,000
	Restroom exhaust fan	1	ea	1,000.00	1,000
	Thru wall air conditioner/heating unit	1	ea	3,000.00	3,000
	Subtotal Mechanical		\$/SF:	6.26	19,000

15.P	PLUMBING				
	Plumbing, per fixture	5	ea	5,000.00	25,000
	Subtotal Plumbing		\$/SF:	8.24	25,000

16.0	ELECTRICAL				
	Equipment, switchgear, panelboards, etc.	3,035	sf	5.00	15,174
	Power, convenience, hvac, etc.	3,035	sf	5.00	15,174
	Lighting and controls	3,035	sf	8.00	24,278
	Fire alarm	3,035	sf	3.00	9,104
	Telecom	3,035	sf	3.00	9,104

ESTIMATE DETAIL

Project:	Hammil Valley Emergency Services Station	Date:	6/30/2011
Level:	Budget Package	Estimator:	Javier Silva
Client:	HMR Architects	Schedule:	
Location:	Apparatus Building - Phase 3	Area (SF):	3,035

ITEM	DESCRIPTION	QUANTITY	UNIT	UNIT COST	TOTAL AMOUNT
	Exterior speaker system	3,035	sf	1.00	3,035
	Security	3,035	sf	1.00	3,035
	Subtotal Electrical		\$/SF:	26.00	78,904

ESTIMATE DETAIL

Project:	Hammil Valley Emergency Services Station	Date:	6/30/2011
Level:	Budget Package	Estimator:	Javier Silva
Client:	HMR Architects	Schedule:	
Location:	Helipad - Phase 4	Area (SF):	3,850

ITEM	DESCRIPTION	QUANTITY	UNIT	UNIT COST	TOTAL AMOUNT
------	-------------	----------	------	-----------	--------------

1	HELIPAD				
	Helipad, 6", bar reinforced	3,850	sf	9.00	34,650
	Add for helipad markings	1	ls	5,000.00	5,000
	Wind sock	1	ea	1,748.00	1,748
	Helipad lights	32	ea	750.00	24,000
	Landing lights	5	ea	750.00	3,750
	Windsock light	1	ea	750.00	750
	Subtotal Helipad		\$/SF:	18.16	69,898

SUBTOTAL		69,898
GENERAL CONDITIONS	10.00%	6,990
BONDS & INSURANCE	2.00%	1,538
OVERHEAD & PROFIT	2.00%	1,569
DESIGN CONTINGENCY	15.00%	11,999
ESCALATION	1.00%	920
TOTAL CONSTRUCTION COST		92,913
	TOTAL \$/SF:	24.13

ESTIMATE SUMMARY

Project:	Hamml Valley Emergency Services Station	Date:	6/30/2011
Level:	Budget Package	Estimator:	Javier Silva
Client:	HMR Architects	Schedule:	0
Location:	Residence Building - Phase 5	Area (SF):	1,125

ITEM	DESCRIPTION	UNIT COST	TOTAL AMOUNT
------	-------------	-----------	--------------

2.0	DEMOLITION	\$/SF:	-	-
3.0	CONCRETE	\$/SF:	21.49	24,173
4.0	MASONRY	\$/SF:	-	-
5.0	METALS	\$/SF:	-	-
6.R	ROUGH CARPENTRY	\$/SF:	48.75	54,849
6.F	FINISH CARPENTRY	\$/SF:	7.91	8,900
7.0	THERMAL & MOISTURE PROTECTION	\$/SF:	30.79	34,639
8.0	DOORS & WINDOWS	\$/SF:	15.73	17,700
9.0	FINISHES	\$/SF:	34.63	38,963
10.0	SPECIALTIES	\$/SF:	2.09	2,350
11.0	EQUIPMENT	\$/SF:	4.44	5,000
12.0	FURNISHINGS	\$/SF:	1.39	1,560
13.0	SPECIAL CONSTRUCTION	\$/SF:	-	-
14.0	CONVEYING	\$/SF:	-	-
15.F	FIRE PROTECTION	\$/SF:	5.00	5,625
15.M	MECHANICAL	\$/SF:	7.50	8,438
15.P	PLUMBING	\$/SF:	24.89	28,000
16.0	ELECTRICAL	\$/SF:	26.00	29,250

SUBTOTAL		259,446
GENERAL CONDITIONS	10.00%	25,945
BONDS & INSURANCE	2.00%	5,708
OVERHEAD & PROFIT	2.00%	5,822
DESIGN CONTINGENCY	15.00%	44,538
ESCALATION	1.00%	3,415
TOTAL CONSTRUCTION COST		344,874
	TOTAL \$/SF:	306.55

ESTIMATE DETAIL

Project:	Hammil Valley Emergency Services Station	Date:	6/30/2011
Level:	Budget Package	Estimator:	Javier Silva
Client:	HMR Architects	Schedule:	
Location:	Residence Building - Phase 5	Area (SF):	1,125

ITEM	DESCRIPTION	QUANTITY	UNIT	UNIT COST	TOTAL AMOUNT
------	-------------	----------	------	-----------	--------------

2.0	DEMOLITION				
	None				
	Subtotal Demolition		\$/SF:		

3.0	CONCRETE				
	5" slab on grade, reinforcing, vapor barrier, rock and sand	1,125	sf	9.30	10,463
	Footings and grade beams, incl. excavation/reinforcing, etc.	1,125	sf	10.00	11,250
	6" curb around perimeter of building	123	lf	20.00	2,460
	Subtotal Concrete		\$/SF:	21.49	24,173

4.0	MASONRY				
	None				
	Subtotal Masonry		\$/SF:		

5.0	METALS				
	None				
	Subtotal Metals		\$/SF:		

6.R	ROUGH CARPENTRY				
	2x6 exterior wall framing with plywood sheathing exterior	1,620	sf	10.60	17,172
	Roof truss framing with plywood sheathing	1,784	sf	10.00	17,844
	Soffit framing, sheathing, finish	471	sf	10.00	4,710
	Interior wall framing	1,250	sf	7.60	9,498
	Post and beam allowance	1,125	sf	5.00	5,625
	Subtotal Rough Carpentry		\$/SF:	48.75	54,849

ESTIMATE DETAIL

Project:	Hammil Valley Emergency Services Station	Date:	6/30/2011
Level:	Budget Package	Estimator:	Javier Silva
Client:	HMR Architects	Schedule:	
Location:	Residence Building - Phase 5	Area (SF):	1,125

ITEM	DESCRIPTION	QUANTITY	UNIT	UNIT COST	TOTAL AMOUNT
------	-------------	----------	------	-----------	--------------

6.F	FINISH CARPENTRY				
	Kitchen base cabinets	17	lf	300.00	5,100
	Kitchen upper cabinets	10	lf	200.00	2,000
	Lavatory cabinets	8	lf	200.00	1,600
	Closet shelf & pole	8	lf	25.00	200
	Subtotal Finish Carpentry		\$/SF:	7.91	8,900

7.0	THERMAL & MOISTURE PROTECTION				
	Exterior wall insulation	1,620	sf	1.50	2,430
	Interior wall insulation	1,250	sf	1.25	1,562
	Roof insulation	1,125	sf	2.00	2,250
	Standing seam metal roofing	1,784	sf	15.00	26,766
	Gutters/downspouts	135	lf	10.00	1,350
	Sealants and caulking	1,125	sf	0.25	281
	Subtotal Thermal & Moisture Protection		\$/SF:	30.79	34,639

8.0	DOORS & WINDOWS				
	Exterior hm doors, frames and hardware	4	ea	1,500.00	6,000
	Interior wd doors, frames and hardware	5	ea	500.00	2,500
	Sliding closet doors	2	ea	700.00	1,400
	Exterior windows	156	sf	50.00	7,800
	Subtotal Doors & Windows		\$/SF:	15.73	17,700

9.0	FINISHES				
	Exterior Finishes				
	Cement board siding, painted	1,620	sf	6.50	10,530
	Drywall Assemblies				
	Drywall to wall framing	4,120	sf	2.25	9,269

ESTIMATE DETAIL

Project:	Hammil Valley Emergency Services Station	Date:	6/30/2011
Level:	Budget Package	Estimator:	Javier Silva
Client:	HMR Architects	Schedule:	
Location:	Residence Building - Phase 5	Area (SF):	1,125

ITEM	DESCRIPTION	QUANTITY	UNIT	UNIT COST	TOTAL AMOUNT
------	-------------	----------	------	-----------	--------------

	Floor Finishes				
	Sheet vinyl	479	sf	1.00	479
	Carpet	646	sf	4.00	2,582
	Rubber base	244	lf	3.00	733
	Ceiling Finishes				
	Painted drywall ceilings	1,125	sf	10.00	11,250
	Wall Finishes				
	Paint drywall	4,120	sf	1.00	4,120
	Subtotal Finishes		\$/SF:	34.63	38,963

10.0	SPECIALTIES				
	Restroom accessories	2	ea	500.00	1,000
	Grab bars	2	ea	350.00	700
	Shower seat	1	ea	650.00	650
	Subtotal Specialties		\$/SF:	2.09	2,350

11.0	EQUIPMENT				
	Refrigerator	1	ea	1,500.00	1,500
	Stove/hood	1	ea	1,500.00	1,500
	Washer/dryer	1	set	2,000.00	2,000
	Subtotal Equipment		\$/SF:	4.44	5,000

12.0	FURNISHINGS				
	Window blinds	156	sf	10.00	1,560
	Subtotal Furnishings		\$/SF:	1.39	1,560

13.0	SPECIAL CONSTRUCTION				
	None				

ESTIMATE DETAIL

Project:	Hammil Valley Emergency Services Station	Date:	6/30/2011
Level:	Budget Package	Estimator:	Javier Silva
Client:	HMR Architects	Schedule:	
Location:	Residence Building - Phase 5	Area (SF):	1,125

ITEM	DESCRIPTION	QUANTITY	UNIT	UNIT COST	TOTAL AMOUNT
------	-------------	----------	------	-----------	--------------

	Subtotal Special Construction		\$/SF:		
--	-------------------------------	--	--------	--	--

14.0	CONVEYING				
	None				
	Subtotal Conveying		\$/SF:		

15.F	FIRE PROTECTION				
	Wet pipe fire sprinkler system	1,125	sf	5.00	5,625
	Subtotal Fire Protection		\$/SF:	5.00	5,625

15.M	MECHANICAL				
	Residential HVAC system	1,125	sf	7.50	8,438
	Subtotal Mechanical		\$/SF:	7.50	8,438

15.P	PLUMBING				
	Plumbing, per fixture	8	ea	3,500.00	28,000
	Subtotal Plumbing		\$/SF:	24.89	28,000

16.0	ELECTRICAL				
	Equipment, switchgear, panelboards, etc.	1,125	sf	5.00	5,625
	Power, convenience, hvac, etc.	1,125	sf	5.00	5,625
	Lighting and controls	1,125	sf	8.00	9,000
	Fire alarm	1,125	sf	3.00	3,375
	Telecom	1,125	sf	3.00	3,375
	Exterior speaker system	1,125	sf	1.00	1,125
	Security	1,125	sf	1.00	1,125

ESTIMATE DETAIL

Project:	Hammil Valley Emergency Services Station	Date:	6/30/2011
Level:	Budget Package	Estimator:	Javier Silva
Client:	HMR Architects	Schedule:	
Location:	Residence Building - Phase 5	Area (SF):	1,125

ITEM	DESCRIPTION	QUANTITY	UNIT	UNIT COST	TOTAL AMOUNT
	Subtotal Electrical		\$/SF:	26.00	29,250

SECTION 01910 – COMMISSIONING (Required if project LEED certified.)

PART 1 - GENERAL

1.01 SUMMARY

- A. Perform and document commissioning. This Section supplements, but does not supersede specific testing requirements found elsewhere in the Contract Documents.
- B. General Responsibilities
 - 1. Provide all materials, labor and documentation to execute the commissioning activities as described in the Contract Documents.
 - 2. Provide a Quality Assurance Manager.
 - 3. Coordinate the Commissioning work and ensure that commissioning responsibilities of all trades are executed according to the Contract Documents.
 - 4. Include commissioning activities in the contract schedule.
 - 5. Attend commissioning meetings.

1.02 RELATED WORK AND DOCUMENTS

1.03 ABBREVIATIONS AND DEFINITIONS

1.04 COORDINATION

1.05 SUBMITTALS

- A. Documentation supporting Quality Assurance Manager qualifications as required in the Quality Assurance article.
- B. Installation/Start-up Verification Checklists
- C. Functional Performance Checklists
- D. Commissioning Schedule
- E. Final Commissioning Binders and CD
 - 1. Burning: Not permitted.
 - 2. Disposal: Off State' property.
 - 3. Landfill records for hazardous wastes.

PART 2 – PRODUCTS (NOT USED)

PART 3 – EXECUTION

3.01 QUALITY CONTROL

- 3.02 COMMISSIONING BINDERS
- 3.03 SYSTEM INSTALLATION
- 3.04 SYSTEM START UP
- 3.05 FUNCTIONAL PERFORMANCE TESTING
 - A. Equipment Functional Performance Testing
 - B. Operational Tests
 - C. System Functional Performance Tests
 - D. Test Equipment
 - E. Calibration of Installed Sensing Equipment\
- 3.06 SEASONAL/DEFERRED TESTING

END OF SECTION

SECTION 02100 - DEMOLITION, REMOVALS, AND SITE PREPARATION

PART 1 - GENERAL

1.01 SUMMARY

- A. Demolish and remove barbed wire fencing as required for driveway and offsite improvements on Highway 6.

1.02 PROJECT CONDITIONS

- A. Hazardous Materials: Present; remediation specified elsewhere.

1.03 EXECUTION

- A. Existing Utilities: Shutoff by Contractor.
 - 1. Notice of Service Shutdown: 72 hours.
- B. Mechanical Demolition:
 - 1. Site improvements demolished systematically.
- C. Site Restoration:
 - 1. Below-Grade Areas: Rough grade for new construction and fill other areas with backfill.
 - 2. Site Grading: Uniformly graded.
- D. Recycling Demolished Materials:
 - 1. Recyclable materials separated by type from other demolished materials.
- E. Disposal of Demolished Materials:
 - 1. Burning: Not permitted.
 - 2. Disposal: Off State' property.
 - 3. Landfill records for hazardous wastes.

END OF SECTION

SECTION 02200 - EARTHWORK

PART 1 - GENERAL

1.01 DESCRIPTION

- A. Related Documents:
- B. Section Includes: Description of the requirements for the following:
 - 1. Excavating, filling, compaction and grading for drainage to yard drain locations and to set finished elevations indicated on the Drawings.
 - 2. Preparation of subgrade for slabs, footings and paving.
 - 3. Earthwork required for utility runs and modifications.
 - 4. Cleaning and grubbing.
 - 5. Removals of excess dirt.
 - 6. Grading for access roads and parking lots.
 - 7. Compliance with Geotechnical Soils Report.
 - 8. Grading for helipad.
- C. Related Sections:
 - 1. Division 1: Quality Control
 - 2. Division 1: Test Inspection Services
 - 3. Section 02010: Geotechnical Soils Report and Geologic Hazards Report.
 - 4. Section 02222: Excavating, Backfilling and Compacting for Structures.
 - 5. Division 15/16: Excavation and Backfill for Mechanical and Electrical Work, except as included herein.

1.02 QUALITY ASSURANCE

- A. Requirements of Regulatory Agencies.
- B. References and Standards.
- C. Observation and Testing.

1.03 PROTECTION

- A. Bulkheading and Shoring.
- B. Surface Drainage.
- C. Pumping.
- D. Dust Control.

1.04 JOB CONDITIONS

- A. Seasonal limits.
- B. Existing site conditions.
- C. Natural features.
- D. Noise producing activities.
- E. Dust control.
- F. Erosion control.

1.05 CLEAN-UP AND DISPOSAL

- A. Clean-Up.
- B. Disposal.

1.06 PRODUCT DELIVERY AND STORAGE OF BULK SOIL

1.07 DRAINAGE MAINTENANCE

1.08 TEMPORARY SUSPENSION OF THE WORK

1.09 CUT/FILL

1.10 LANDSCAPING

PART 2 - PRODUCTS

2.01 MATERIALS

- A. Local and imported fill.
- B. Topsoil Material.
- C. Water.

PART 3 - EXECUTION

3.01 LAYOUT AND PREPARATION

- A. Refer also to Division 1.
- B. Provide over-excavation at all structural footings per soils report.

3.02 SITE PREPARATION

- A. General: Demolition, Removals and Site Preparation.
- B. Preparation of Surfaces to Receive Fill.
- C. Moisture content.
- D. Compaction.
- E. Removal of Water.
- F. Plan for Excavation.
- G. Dewatering.

3.03 PLACING, SPREADING AND COMPACTING FILL MATERIAL

3.04 EXCAVATIONS

3.05 FINAL SUBGRADE PREPARATION

3.06 GRADING FOR CONCRETE SLABS AND PAVING/PATCHWORK

3.07 SITE FINISH GRADING

3.08 APPLICATION

3.09 FIELD QUALITY CONTROL

3.10 ADJUST AND CLEAN

3.11 INSPECTION

3.12 MISCELLANEOUS WORK

END OF SECTION

SECTION 02222 - EXCAVATION, BACKFILLING AND COMPACTING FOR UTILITIES

PART 1 - GENERAL

1.01 SUMMARY

- A. Trenching and backfilling for site utilities.
- B. Provide all necessary shoring and bracing of excavations over five feet in depth.
- D. Place pipe bedding material extending from bottom of trench to 12 inches above top of pipe. Pipe bedding material shall be self-compacting meeting the following gradations: 75% to 95% passing 3/8" sieve, 10% to 25% passing #4 sieve and 0 to 8% passing #200 sieve.
- E. Trench backfill material from 12 inches above top of pipe to subgrade. Trench backfill material shall be class 2 aggregate base in accordance with Section 26 of the Caltrans Standard Specification.
- F. Trench backfill shall be placed in lifts with a maximum uncompacted thickness of 8 inches. Each layer shall be spread evenly and thoroughly mixed to obtain a near uniform condition in each layer. Backfill shall then be brought to a uniform moisture content of about 2 to 5 percent over optimum, mixed as required to establish uniform moisture and compacted to a minimum of 90 percent of the maximum dry density as determined by ASTM D1557.
- G. Bury all utilities to the grades indicated on the plans or a minimum of twenty-four inches below finish grade.
- H. Support utility lines for entire length on undisturbed original soil or compacted backfill.
- I. Provide thrust blocks for lines under liquid pressure.

END OF SECTION

SECTION 02510 - ASPHALT CONCRETE PAVING

PART 1 - GENERAL

1.01 DESCRIPTION

- A. Furnish materials, labor, equipment and services necessary and incidental for the installation of asphaltic concrete paving, as shown on the drawings and as specified herein.
- B. Work included consists of, but is not limited to, the following:
 - 1. New asphaltic concrete paving areas such as driveways and parking lots.
 - 2. Painting and striping of paved areas.

1.02 RELATED SECTIONS

- A. The requirements of Division 1 apply to the Work of this Section.
- B. Section 02200: Earthwork
- C. Section 02222: Trenching and Backfilling for Utilities

1.03 QUALITY ASSURANCE

- A. Geotechnical and Topographical Reports: See Section 31 00 00 Earthwork.
- B. Regulatory Requirements:
 - 1. Asphaltic concrete shall be designed, manufactured and installed in accordance with the requirements of the American Society of Testing Materials (ASTM) and The Asphalt Institute (TAI) and shall meet the minimum requirements of the latest editions of the following regulations and standards, which are hereby included in and made a part of these specifications:
 - a. Local Requirements: All work falling under the jurisdiction of the City of Portola.
 - b. TAI - Manual MS-2-Mix Design Methods for Asphaltic Concrete.
 - c. TAI - Manual MS-3 Asphalt Plant Manual.
 - d. TAI - Manual MS-8 Asphalt Paving Manual.
 - e. TAI - MS-19 Basic Asphalt Emulsion Manual.
 - f. American Association of State Highway and Transportation Officials (AASHTO) - Standard Specifications for Construction of Roads and Bridges.
 - g. ASTM D946 - Penetrating - Graded asphalt - cement for use in pavement construction.
 - 2. Maintain one (1) copy of the above noted references on the job site for reference at all times.
- C. Mix Design: Asphaltic concrete mix designs shall be prepared under the direct supervision of a Professional Civil Engineer experienced in their preparation, and licensed in the state of California

- D. Warranty: Warrant asphaltic concrete paving against defects in materials and workmanship for a period of 5 years.

1.03 SUBMITTALS

1.04 HANDLING AND STORAGE

- A. Asphaltic concrete aggregate stockpiles shall be arranged and used at the plant to avoid segregation and contamination. Frozen or partially frozen aggregates shall not be used.
- B. No asphaltic concrete materials shall be stored on site.

1.05 JOB CONDITIONS

1.06 ENVIRONMENTAL REQUIREMENTS

PART 2 – PRODUCTS

2.01 GENERAL REQUIREMENTS

- A. All materials used in the asphaltic concrete paving work shall be obtained from the same source and/or manufacturer throughout the entirety of the project.

2.02 AGGREGATE

- A. The aggregate for the asphaltic concrete shall consist of crushed stone or gravel (slag of any type will not be permitted) meeting the requirements of ASTM D-448 for coarse aggregate, ASTM D-1073 for fine aggregate and ASTM D-242 for mineral filler.
- B. The gradation of the crushed aggregate shall be a mixture of coarse aggregate, retained on a No. 8 sieve, fine aggregate, passing a No. 8 sieve and mineral filler passing the No. 200 sieve conforming to the following "Master Job Mix Formula" for the binder and wearing course.
 - 1. Master Job Mix Formula - Binder Course

Sieve Size	Percent Passing By Weight	Job Mix Tolerances
1-1/2"	100	±7
1"	80 -100	±7
3/4"	70 - 100	±7
3/8"	55 - 75	±7
No. 4	45 - 62	±7
No. 8	35 - 50	±4

Sieve Size	Percent Passing By Weight	Job Mix Tolerances
No. 30	19 - 30	± 4
No. 50	19 - 23	± 4
No. 100	7 - 15	± 4
No. 200	1 - 8	± 2

2. Master Job Mix Formula - Wearing Course

Sieve Size	Percent Passing By Weight	Job Mix Tolerances
3/4"	100	± 7
1/2"	80 - 100	± 7
3/8"	70 - 90	± 7
No. 8	35 - 50	± 4
No. 30	18 - 29	± 4
No. 50	13 - 23	± 4
No. 100	8 - 16	± 4
No. 200	4 - 10	± 2

3. When wearing course has a thickness of 1" or less compacted depth the gradation of the aggregate shall be modified to permit 100% to pass the 1/2" sieve, 80% - 100% to pass the 3/8" sieve and 55% - 75% to pass the No. 4 sieve.

- C. Cal Trans State Highway department specifications closely conforming to the above "Master Job Mix Formula" and approved by the Soils Engineer may be substituted; however, job mix tolerances shall be maintained.
- D. Maximum aggregate size shall be no greater than one-half of the design thickness of the binder or wearing course. Gradation percentages shall closely parallel the median wherever possible.
- E. Do not store reclaimed asphalt concrete or aggregate base with reclaimed asphalt concrete within 100 feet measured horizontally of any culvert, watercourse, or bridge.

2.03 ASPHALTIC CONCRETE MIX

- A. Asphalt cement for asphaltic concrete mixture shall be Penetration Grade 60-70 or 85-100 conforming to AASHTO designation M20 or Viscosity Grade AC-20 conforming to AASHTO designation M-226.
 - 1. Binder course shall contain 4.5% to 6% by weight of mixture of asphalt cement.

2. Wearing course shall contain 5% to 7% by weight of mixture of asphalt cement.
- B. Asphalt for tack coat shall be slow setting emulsified asphalt SS-1 or SS-1h conforming to AASHTO designation M-140.
 - C. Cracking Sealant: ASTM D3405 or ASTM D1190.
 - D. Plant mixed asphaltic concrete mixture shall meet the following requirements when tested by the Marshall Method, ASTM D-1559. The requirements are based on the asphaltic concrete being compacted with 50 blows and tested at 140 degrees F.

Physical Test	Binder Course	Wearing Course
Stability (min.)	1500 psi	1500 psi
Flow (1/100")	6 - 18	6 - 18
Total Voids (%)	2 - 5	3 - 6

1. Asphalt cement content shall be 4.5 - 7.0 percent by weight of total mix (See Item A). Upper limit may be raised when using absorbent aggregate.
2. Optimum asphalt cement content shall be determined by the Marshall Method test property curve. The amount of asphalt cement shall be selected to meet specified stability and flow requirements. A 1% tolerance in air voids is permitted.
3. Use dry material to avoid foaming. Mix uniformly and thoroughly.

2.04 GEOTEXTILE FABRIC

- A. The fabric shall be needle punched, non-woven, thermally bonded on one side 100% polypropylene staple fiber fabric, conforming to the following:
 1. Tensile Strength, either direction – ASTM D4632 101 Lbs/kn minimum
 2. Elongation at Break, either direction- ASTM D4632 50% minimum.
 3. Mullen Burst Strength – ASTM D3786 180 PSI minimum
 4. Weight – ASTM D3776 4.1 oz/SY minimum
 5. Asphalt Retention by Fabric ASTM D6140 26.9 oz/SY residual min
- B. Provide a Certificate of Compliance for the paving fabric used on the project to project Architect for approval. Paving fabric shall be delivered to job site with protective cover capable of protecting the fabric from Ultraviolet ray, abrasion and water.
- C. Fabric shall be Mirapave 500 as manufactured by MIRAFI Construction Products, (706-693-2226) or equal.
- D. Tack Coat shall be per the fabric manufactures recommendation and compatible with the finished asphaltic concrete courses.

2.05 ASPHALTIC CONCRETE PAVEMENT DESIGN

- A. Asphaltic pavement shall be as shown on the drawings, and shall have the minimum compacted thicknesses as detailed on the drawings and as specified in the governing soils report.
- B. All thicknesses are compacted thicknesses. See site drawings for extent and type of paving locations.

PART 3 – EXECUTION

3.01 EXAMINATION

- A. Verify that the aggregate base course has adequate compaction, is stabilized and dry and is adequate to support paving imposed loads. Aggregate base course must be approved by the Soils Engineer prior to beginning paving operations.

3.02 PREPARATION

3.03 INSTALLATION

3.04 TOLERANCES

3.05 FIELD QUALITY CONTROL

3.06 CLEAN UP

END OF SECTION

SECTION 02520 - CONCRETE CURBS, SIDEWALKS AND PAVING

PART 1 – GENERAL

1.01 REQUIREMENTS

- A. All applicable portions of Division 1 - General Requirements are to be considered as included with this section.

1.02 CODES

1.03 DESCRIPTION

- A. Furnish all materials, labor, equipment, services, etc., necessary and incidental for the completion of all Portland Cement concrete curbs, walks and helipad as shown on the drawings and as specified herein.

1.04 RELATED SECTIONS

- A. Related work specified elsewhere.

1.05 SUBMITTALS

1.06 DELIVERY, STORAGE, AND HANDLING

1.07 QUALITY ASSURANCE

- A. Building Code of the City, County and State in which this development is located.
- B. State Highway or Department of Transportation Specifications in which this development is located if applicable.
- C. Manuals of Standard Practice of the Concrete Reinforcing Steel Institute (CRSI) and the Western Concrete Reinforcing Steel Institute (WCRSI).
- D. American Concrete Institute (ACI), "Recommended Practice for Concrete Formwork" ACI 347.
- E. American Concrete Institute (ACI), "Specifications for Structural Concrete for Buildings", ACI 301.
- F. American Concrete Institute (ACI), "Recommend Practice for Concrete Floor and Slab Construction", ACI 302.
- G. American Concrete Institute (ACI), "Recommended Practice for Measuring, Mixing, Transporting and Placing Concrete" ACI 304.
- H. American Concrete Institute (ACI) "Recommended Practice for Hot Weather Concreting", ACI 305R.
- I. American Concrete Institute (ACI) "Recommended Practice for Cold Weather Concreting", ACI 306R.
- J. American Concrete Institute (ACI) "Building Code Requirements for Reinforced Concrete", ACI 318.
- K. "Standard Specifications for Construction of Roads and Bridges", American Association of State Highway and Transportation Officials (AASHTO).

1.08 JOB CONDITIONS

1.09 ENVIRONMENTAL REQUIREMENTS

1.10 WARRANTY

- A. This contractor shall warrant all materials and workmanship. See Division 1 of the Specifications.

PART 2 – PRODUCTS

2.01 MATERIALS

2.02 ADMIXTURES

2.03 ACCESSORIES

2.04 CONCRETE MIX

2.05 CONCRETE PRODUCTION

2.06 FABRICATION

PART 3 – EXECUTION

3.01 EXAMINATION

3.02 PREPARATION

3.03 INSTALLATION

3.04 CONCRETE FINISH

3.05 CURING AND PROTECTION

3.06 TOLERANCES

3.07 FIELD QUALITY CONTROL

3.08 DEFECTIVE CONCRETE

3.09 REPAIRING AND PATCHING

3.10 FIELD QUALITY CONTROL

3.11 CLEAN UP

END OF SECTION

SECTION 02580 - PAVEMENT MARKING AND SIGNAGE

PART 1 - GENERAL

1.01 Requirements

1.02 Codes

1.03 Description

A. Provide pavement markings at parking lot and helipad per drawings.

1.04 Related Sections

1.05 Delivery, Storage and Handling

1.06 Quality Assurance

1.07 Job Conditions

1.08 Warranty

PART 2 - PRODUCTS

2.01 Material

2.02 Manufacturers

PART 3 - EXECUTION

3.01 Examination

3.02 Installation

3.03 Tolerances

3.04 Field Quality Control

3.05 Clean-Up

END OF SECTION

SECTION 02660 - WATER SYSTEM

PART 1 - GENERAL

1.01 SUMMARY

- A. Piping for potable-water service outside the building.
- B. Piping for fire-protection water service outside the building.
- C. Well for domestic and fire protection water supply.

1.02 SYSTEM PERFORMANCE

- A. Potable-Water-Service Minimum Working-Pressure Rating: 160 psig.

1.03 SUBMITTALS

- A. Coordination Drawings.

1.04 MATERIALS

- A. Pipe and Fittings:
 - 1. Ductile-iron pipe and push-on fittings with gasketed joints.
 - 2. Class 200 PVC plastic fire-service pipe and ductile-iron fittings with gasketed joints.

1.05 COMPONENTS

- A. Piping Specialties:
 - 1. Flexible connectors.
 - 2. Dielectric Fittings: Unions, Flanges, Couplings and Nipples.
- B. Polyethylene encasement for ductile-iron piping.
- C. Valves:
 - 1. AWWA gate valves, non-rising stem.
 - 2. Valve boxes.
 - 3. Indicator posts.
- D. Specialty Valves: Pressure regulating and Flow regulating.
- E. Detector check valves.
- F. Backflow Preventers: Reduced pressure principle backflow prevention assembly and reduced pressure principle backflow prevention detector assembly.

- G. Alarm Devices: Water-flow indicators, Supervisory switches and Pressure switches.
- H. Detectable plastic underground warning tape.
- I. Well pump.

END OF SECTION

SECTION 02685 - GAS DISTRIBUTION SYSTEM

PART 1 - GENERAL

1.01 SUMMARY

- A. Propane gas distribution outside the building.

1.02 SYSTEM PERFORMANCE

- A. Minimum Working-Pressure Ratings:
 - 1. Piping and Valves: 100 psig.
 - 2. Service Regulators: 100 psig.
 - 3. Service Meters: 65 psig.

1.03 MATERIALS

- A. Pipes: Polyethylene plastic.
- B. Shutoff Valves: Lubricated tapered plug, Ball, Lubricated plug.
- C. Valve boxes.
- D. Service Regulators: Single-stage, steel jacketed.
- E. Service Meters: Positive-displacement type.
- F. Earthquake, automatic shutoff.
- G. Underground warning tape.
- H. Concrete bases.

1.04 INSTALLATION

- A. Service Piping: Underground.

END OF SECTION

SECTION 02720 - STORM DRAIN SYSTEM

PART 1 - GENERAL

1.01 SUMMARY

- A. Storm drainage outside the building, including gravity-flow piping.

1.02 SYSTEM PERFORMANCE

- A. Gravity-Flow, Nonpressure-Piping Pressure Rating: Systems test pressure.

1.03 SUBMITTALS

- A. Coordination Drawing.

1.04 MATERIALS

- A. Pipes and Fittings:

- 1. Reinforced concrete pipe.
- 2. Corrugated-steel pipe with banded joints.

- B. Special Pipe Couplings and Fittings:

- 1. Pipe Couplings: Sleeve type.

- C. Manholes: Normal-traffic precast concrete and/or Cast-In-Place concrete with frames and grates.

- D. Catch Basins: Normal-traffic precast concrete and/or Cast-In-Place concrete with frames and grates.

- E. Stormwater Inlets: Curb gutter combination inlets.

- F. Backwater Valves: Gray iron.

- G. Stormwater Clarifier: oil and water separation tanks, precast concrete, 2,500-gallon capacity.

- H. Pipe Outlets: Cast-In-Place concrete head walls with riprap.

END OF SECTION

SECTION 02730 - SEWER SYSTEM

PART 1 - GENERAL

1.01 SUMMARY

- A. Sanitary sewerage outside the building, including gravity-flow piping.

1.02 SUBMITTALS

- A. Coordination Drawings.

1.03 MATERIALS

- A. Pipes and Fittings:

- 1. PVC sewer pipe and fittings with bell and spigot gasketed joints.
- 2. PVC profile gravity sewer pipe and fittings with bell and spigot gasketed joints.

- B. Manholes: Normal-traffic precast concrete and/or Cast-In-Place concrete with frames and covers.

- C. Cleanouts: Gray iron.

- D. Septic tank

1.04 OBTAIN COUNTY PERMITS & INSPECTIONS AS REQUIRED BY LOCAL AUTHORITY

END OF SECTION

SECTION 02810 - IRRIGATION SYSTEM

PART 1 - GENERAL

1.01 SUMMARY

- A. Pipe and fittings, valves, sprinklers, controls, wiring, trenching, backfill and programming.

1.02 SYSTEM PERFORMANCE

- A. Minimum Water Coverage: 100 percent overlap of heads.

1.03 SUBMITTALS

- A. Approval of all parts and equipment prior to installation.

1.04 MATERIALS

A. Piping:

1. Aboveground, Pressure piping: Type K.
2. Underground, Pressure Piping: Schedule 40 PVC pipe.
3. Circuit Piping: SDR 21 PVC pressure-rated pipe.
4. Drip Emitter Distribution Tubing: 0.25" O.D. vinyl tubing.
5. Underground Branches at Sprinklers and Devices: Schedule 80 PVC pipe.
6. Risers to Aboveground Sprinklers and Specialties: Schedule 80 PVC pipe.

B. Valves:

7. Aboveground, Shut-off-Duty: Bronze ball valve.
8. Underground, Shutoff Duty: Bronze Gate valve.
9. Underground, Manual Control: Bronze gate valve.
10. Control: Plastic diaphragm valve.

C. Valve Boxes: Molded plastic or concrete with cast-iron lid in traffic areas.

D. Sprinklers: Bubbler, Pop-up, fixed-pattern spray.

E. Specialties: Pressure regulators, Single-outlet emitters, Multiple-outlet emitters, Drip tubes.

F. Automatic Control System: Low voltage, with exterior control enclosure, transformer, timing device and wiring.

1.05 FIELD QUALITY CONTROL

- A. Hydrostatically test piping and valves before backfilling.
- B. Operate on automatic mode prior to installation of planting.
- C. Commissioning activities.

END OF SECTION

SECTION 02830 - CHAIN LINK FENCING

PART 1 - GENERAL

1.01 SUMMARY

- A. Standard industrial fencing, consisting of wire mesh.

1.02 MATERIALS

- A. Wire Mesh Fabric:
 - 1. ASTM A116, Class 1.
- B. Framework:
 - 1. Galvanized Steel: Type I round.
- C. Gates: Swinging, metal pipe type.

1.03 INSTALLATION

- A. Install fencing with top rail.
- B. Install fencing with bottom rail.

END OF SECTION

SECTION 02900 - LANDSCAPE PLANTING

PART 1 - GENERAL

1.01 SUMMARY

- A. Planting includes the layout, soil preparation, excavation for and planting of landscape materials, including seeded lawn, containerized trees and shrubs.

1.02 SUBMITTALS

- A. Seed and container plants and nursery sources.
- B. Soil amendments.
- C. Mulch, tree stakes and ties.

1.03 WARRANTY

- A. Plantings in healthy growing condition: One year.

1.04 PLANT ESTABLISHMENT PERIOD

- A. All plantings: 60 calendar days following installation. Maintain until acceptance of project.

1.05 MATERIALS

- A. Containerized trees and shrubs: Graded to American Standard for Nursery Stock, ANSI Z60.1.
- B. Topsoil: Amend existing topsoil and add approved imported topsoil to make required grades.
- C. Soil Amendments: Bagged or bulk form in accordance with soil report requirements.
- D. Fertilizers: Pelleted and pill form, general purpose and slow release types.
- E. Mulches: Composted for amending soil, and shredded wood and bark for surface.
- F. Seed: Cool season blend, harvested in current year with certified germination rate.
- G. Miscellaneous materials: Herbicides: lodgepole pine stakes with self-tying acrylic plastic ties.

1.06 INSTALLATION

- A. Complete installation and operate sprinkler systems prior to any plant installation. Complete fine grading and install plants in watering basins and commence irrigation program.

END OF SECTION

SECTION 02960 - EROSION CONTROL

PART 1 - GENERAL

1.01 SCOPE OF WORK

- A. General: Provide all materials, equipment and labor necessary to furnish and install straw wattles or silt fence barriers at locations shown on the Drawings and on Contractors Storm Water Pollution Prevention Plan.
- B. Permit: Prepare a Storm Water Pollution Prevention Plan (SWPPP) tailored to the Contractor's operations, methods and equipment. Comply with State Water Resources Control Board requirements. Obtain and pay for permit in Owner's name from State Water Resources Control Board.
- C. Storm Water Pollution Prevention Plan (SWPPP): The SWPPP shall be provided by the Contractor prior to the start of work. The SWPPP shall be tailored to the contractor's approach to the work in this contract. The Contractor shall as a minimum address:
 - 1. Cut and fill operations
 - 2. Temporary stockpiles
 - 3. Vehicle and equipment storage, maintenance and fueling operations
 - 4. Concrete, plaster, mortar and paint disposal
 - 5. Dust control
 - 6. Tracking of dirt, mud on off-site streets
 - 7. Pipe flushing

1.02 QUALITY ASSURANCE

- A. General: Comply with governing codes and regulations.

1.03 SUBMITTALS

- A. Storm Water Pollution Prevention Plan: The Contractor shall submit and obtain the Storm Water Pollution Prevention Permit prior to beginning work on site.
- B. Notice Of Intent (NOI): The Contractor shall submit a NOI to the State Water Resources Control Board prior to beginning work on site.

PART 2 – PRODUCTS

2.01 MATERIALS

- A. Straw Wattles: Shall be new manufactured straw rolls in compliance with state requirements for sediment control.
- B. Silt Fences: Shall be as detailed in the Drawings.
- C. Filter Bag: Shall be as required by Sacramento County Standards.

PART 3 - EXECUTION

3.01 INSTALLATION

- A. Straw Wattles: Shall be installed per the drawings and/or as required by the SWPPP.
- B. Silt Fences: Shall be installed per the Drawings and/or as required by the SWPPP. Bales shall be placed so that the top of the bale placed around an inlet is not higher than the lowest point of the surrounding grade.
- C. Filter Bags: Shall be installed as required by manufactures requirements.

3.02 MAINTENANCE AND REMOVAL:

- A. General: Maintain and repair existing and new erosion control facilities throughout the construction period. Remove silt build up at straw wattles and/or silt fences as needed. Repair damage to earth slopes and banks. Erosion control measures shall be left in place until final paving and landscaping are complete.
- B. Monitoring: Provide monitoring of erosion control measures before and after storm events. Provide a daily log of construction activities and impact on erosion control measures. Update SWPPP continuously throughout construction period.
- C. Cleaning: Keep area clean of debris.
- D. Remove erosion control measures prior to placing finish landscaping.

END OF SECTION

SECTION 03150 - FORMS

PART 1 - GENERAL

1.01 GENERAL REQUIREMENTS

- A. All applicable portions of Division 1, including the Drawings and General Provisions of the Contract, the General and Supplementary Conditions and Division 1 Specification Sections apply to Work of this Section as if printed herein.

1.02 SCOPE

- A. Design, furnish and install forms for concrete as indicated on drawings and specified here. Remove forms and shores at specified time. Clean up.

1.30 RELATED WORK (See also Table of Contents)

- A. Structural Steel: Section 05120.
- B. Items relating solely to mechanical or electrical work are included under those Divisions, except as specifically indicated otherwise on Drawings.
- C. Reinforcing Steel: Section 03210.
- D. Cast-In-Place Concrete: Section 03301.

1.04 QUALITY ASSURANCE

- A. General:
 - 1. Conform to all requirements of ACI 347 and CBC Section 1906A.1 and 1906A.2.
- B. Standards and References: (Latest Edition unless otherwise noted)

PART 2 - PRODUCTS

2.01 MATERIALS

- A. Form Material:
- B. Fiber Forms.
- C. Form Clamps.
- D. Form Ties:
- E. Spreaders: Metal (no wood).

- F. Form Coating.
- G. Joint Tape.
- H. Expansion Joint Filler.
- I. Extruded Polystyrene Foam.

PART 3 - EXECUTION

- 3.01 FORM CONSTRUCTION
- 3.02 CLEANING OF FORMS
- 3.03 INSPECTION OF FORMS
- 3.04 REMOVAL OF FORMS AND SHORING
- 3.05 ADJUSTING AND CLEANING

END OF SECTION

SECTION 03200 - CONCRETE REINFORCEMENT

PART 1 - GENERAL

1.10 GENERAL REQUIREMENTS

- A. Requirements of Division 1 apply to all work of this Section.

1.02 SCOPE

- A. Unless noted otherwise, furnish and install reinforcing for all concrete, including dowels, chairs, spacers, bolsters, etc., necessary for supporting and fastening reinforcement in place as shown on the Drawings and specified herein.

1.03 RELATED WORK (See also Table of Contents)

- A. Section 03100: Concrete Formwork
- B. Section 03301: Cast-In-Place Concrete
- C. Section 04222: Concrete Unit Masonry (CMU)

1.04 QUALITY ASSURANCE

A. General:

- 1. Acceptable Manufacturers.
- 2. Installer Qualifications.
- 3. Welding Qualifications.
- 4. Reinforcement Work shall conform to ACI 301 and CBC Section 1907A, as minimum standards.
- 5. Allowable Tolerances:

B. Standards and References: (Latest Edition unless otherwise noted):

- 1. American Concrete Institute (ACI).
 - a. ACI 301 - "Specifications for Structural Concrete for Buildings".
 - b. ACI 315 - "Details and Detailing of Concrete Reinforcing".
- 2. American Society for Testing and Materials (ASTM).
 - a. ASTM A82 - "Cold Drawn Wire for Concrete Reinforcement".
 - b. ASTM A185 - "Welded Steel Wire Fabric for Concrete Reinforcement".
 - c. ASTM A615 - "Deformed and Plain Billet-Steel Bars for Concrete

- d. Reinforcement".
ASTM A706 – "Low Alloy Steel Deformed Bars for Concrete Reinforcement".
- 3. Concrete Reinforcing Steel Institute (CRSI) - "Manual of Standard Practice".
- 4. 2001 California Building Code (CBC), Volumes 1, 2, 3, with State of California Amendments.
- C. Submittals: (Submit under provisions of Section 01300)
 - 1. Shop Drawings.
 - 2. Certified mill test reports of supplied reinforcing indicating chemical and physical analysis in accordance with ASTM A615.
 - 3. Product Data:
 - a. Manufacturer's specifications and installation instructions for splice devices.
 - a. Bar Supports.
 - 4. Certificates of Compliance with specified standards:
 - a. Reinforcing bars.
 - b. Welded wire fabric.
 - b. Welding electrodes.
 - 5. Samples: Only as requested by Architect.
- D. Tests and Inspections:

1.05 PRODUCT DELIVERY, STORAGE AND HANDLING

- A. Deliver reinforcement to project site in bundles marked with metal tags indicating bar size and length.
- B. Handle and store materials to prevent contamination.
- C. Deliver and store welding electrodes in accordance with AWS D12.1.

PART 2 - PRODUCTS

2.01 MATERIALS

- A. Reinforcement Bars: ASTM A615, Grade 60.
- B. Stirrups and Ties: ASTM A615, Grade 60.

- C. Steel Dowels: Same grade as bars to which dowels are connected.
- D. Welded wire Fabric: ASTM A185.
- E. Tie Wires: FS-QQ-W-461, annealed steel, black, 16 gauge minimum.
- F. Welding Electrodes: AWS D1.4, low hydrogen, E70XX series.
- G. Bar Supports:
- H. Mechanical Couplers: Comply with CBC sections 1912A.14.3.3 and 1912A.15.4.
- I. Masonry Ties: Comply with CBC requirements.

PART 3 - EXECUTION

3.01 FABRICATION

3.02 CONDITION OF SURFACES

- A. Examine surfaces and conditions receiving or affecting the work. Do not proceed until unsuitable conditions have been corrected.

3.03 GENERAL

- A. Concrete shown without reinforcing shall be reinforced as similar parts shown with reinforcing except where concrete is specifically noted to be unreinforced.

3.04 PLACEMENT

- A. All reinforcement shall be accurately set in place, lapped, spliced, spaced rigidly and securely held in place and tied with specified wire at all splices and crossing points. All wire tie ends shall point away from the form. Carefully locate all dowel steel to align with wall and column steel.
- B. Bar Supports.
- C. Steel Adjustment.
- D. Splices.
- E. Welding.
- F. Welded Wire Fabric.
- G. Reinforcement shall be free of mud, oil or other materials that may reduce bond at the time concrete is placed. Reinforcement with tightly adhered rust or mill scale will be accepted without cleaning provided that rusting has not reduced dimensions and weights below applicable standards. Remove loose rust.

- H. Protection against rust.
- I. Drawing Notes: Refer to notes on Drawings for additional reinforcement requirements.
- J. Mechanical and Electrical Drawings: Refer to Mechanical and Electrical Drawings for formed concrete requiring reinforcing steel. All such steel shall be included under the work of this Section.

END OF SECTION

SECTION 03301 - CAST-IN-PLACE CONCRETE

PART 1 - GENERAL

1.01 SUMMARY

- A. Cast-in-place concrete, including formwork, reinforcement, concrete materials, mix design, placement procedures and finishes for the following:
 - 1. Footings.
 - 2. Slabs-on-grade.
 - 3. Accessible parking and flatwork
 - 4. Helipad

1.02 SUBMITTALS

- A. Design mixes.
- B. Shop Drawings for steel reinforcement.

1.03 MATERIALS

- A. Reinforcement: Deformed Bars Grade 60.
- B. Concrete Materials:
 - 1. Portland Cement: ASTM C150, Type I or II.
 - 2. Aggregates: Normal weight.
 - 3. Admixtures: Air entraining, Water reducing.
- C. Related Materials:
 - 1. Vapor Retarder: Class A polyethylene sheet.
 - 2. Fine graded granular material.
 - 3. Granular fill.
 - 4. Joint-filler strips.
 - 5. Reglets.
 - 6. Dovetail anchor slots.
- D. Floor and Slab Treatments: Unpigmented mineral dry-shake floor hardener.
- E. Curing Materials: Clear waterborne, membrane-forming curing waterborne compound.

1.04 CONCRETE MIXES

- A. Compressive Strength (28 Day):
 - 1. Footings and foundation Walls: 3500 psi.
 - 2. Slabs-on-Grade: 3500 psi.

- B. Mixing: Ready mixed or Project site.

1.05 INSTALLATION

- A. Formed Surface Finishes: Smooth formed.

- B. Floor and Slab Finishes:

1. Scratch: Surfaces to receive mortar setting beds for tile.
2. Float: Surfaces to receive trowel finish.
3. Trowel: Surfaces exposed to view and surfaces to be covered with resilient flooring.
4. Broom: Exterior concrete platforms, steps & ramps.
5. Slip Resistive Aggregate: Concrete stair treads and ramps.
6. Mineral dry shake floor hardener.

1.06 FIELD QUALITY CONTROL

- A. Testing Agency: State employed.

END OF SECTION

SECTION 03480 - PRECAST CONCRETE SPECIALTIES

PART 1 - GENERAL

1.01 SUMMARY

- A. Wheelstops: Standard, prefabricated, reinforced precast product, 72" long x 9" wide x 5-1/4" high with chamfer at top corners; Christy Concrete Products Model M20W7BB or approved equal.

END OF SECTION

SECTION 04200 - MASONRY

PART 1 - GENERAL

1.01 SUMMARY

- A. Exterior Wall Construction:
 - 1. Solid grouted reinforced hollow unit masonry.
- B. Interior Construction:
 - 1. Load-bearing partitions.

1.02 QUALITY ASSURANCE

- A. Independent Testing Lab: masonry units, mortar and grout.

1.03 MATERIALS

- A. Concrete Units: Hollow concrete masonry units, split-face.
- B. Reinforcing: Steel bars ASTM A615 Grade 60.
- C. Embedded Flashing: Sheet metal.
- D. Mortar and Grout.

1.04 INSTALLATION

- A. Bond Pattern: One-half running bond.
- B. Parge below-grade masonry.
- C. Recycle clean masonry waste as fill material.

END OF SECTION

SECTION 05120 - STRUCTURAL STEEL

PART 1 - GENERAL

1.01 SUMMARY

- A. Structural Steel Items:
 - 1. Columns.
 - 2. Rafters for metal building

1.02 QUALITY ASSURANCE

- A. General:
 - 1. Comply with the referenced ASTM standards for materials.
 - 2. Perform all welding only with AWS certified welders.
 - 3. Verification of accuracy:
 - a. Engage and pay for a registered civil engineer or licensed land surveyor to check the alignment, plumbness, elevation, and overall accuracy of the erected framing at appropriate stages during construction and at completion of erection. He shall submit written verification that the entire installation is in accordance with the contract documents.
 - b. Columns shall be verified at each lift. Column shim details and procedures shall be submitted for review.
 - 4. Paint:
 - a. Single Source Responsibility: Provide primers and other undercoat paint produced by same manufacturer as finish coats. Use thinners approved by paint manufacturer, and use within recommended limits.
 - b. Coordination of Work: Review other Sections in which prime paints are to be provided to ensure compatibility of coatings system for various substrates. Upon request, furnish information or characteristics of finish materials to be used.
 - c. Requirements of Regulatory Agencies: Comply with applicable rules and regulations of governing agencies for air quality control.
- B. Except where other requirements are specified, comply with the following standards by American Institute of Steel Construction (AISC) and American Welding Association (AWS):
 - 1. AISC "Specification for Structural Steel Buildings".
 - 2. AISC "Code of Standard Practice for Steel Buildings and Bridges".
 - 3. AISC "Specifications for Structural Joints Using A325 or A490 Bolts".
 - 4. AISC "Specifications for Architecturally Exposed Structural Steel".
 - 5. AWS D1.1 "Structural Welding Code".
 - 6. ASTM A6 "General Requirements for Delivery of Rolled Steel Plates, Shapes, Sheet Piling and Bars for Structural Use".
 - 7. SSPC-Vis 1 Pictorial Surface Preparation Standards for Painting Steel Structures
 - 8. SSPC-SP2 Hand Tool Cleaning
 - 9. SSPC-SP3 Power Tool Cleaning

10. SSPC-SP6 Commercial Blast Cleaning
11. SSPC-PA2 Measurement of Dry Paint Thickness with Magnetic Gauges
12. 2007 California Building Code (CBC) with State of California Amendments

1.03 MATERIALS

- A. Structural Steel: Except where indicated on drawings.
 1. W shapes: ASTM A572-50 or ASTM A992-50 unless indicated otherwise on drawings.
 2. Channels and other rolled shapes: ASTM A36 unless indicated otherwise on drawings.
 3. Angles, plates and bars: ASTM A36 unless indicated otherwise on drawings.
- B. AISC group 4 and 5 shapes and plates greater than 2 inches thick: ASTM A36 and/or ASTM A572 Grade 50 with supplementary requirements S91 Fine Austenitic Grain Size and S5 Charpy V-Notch Impact Test. For location of Charpy V-Notch test, see ASTM A6 Supplementary Requirement S30. Charpy V-Notch test shall be per ASTM A673, frequency P and shall meet a minimum average value of 20 ft-lbs absorbed energy at 70° F.
- C. Cold-Formed Steel Tubing: ASTM A500, Grade B.
- D. Steel Pipe: ASTM A53, Type E or S, Grade B.
- E. Anchor Bolts: All anchor bolts cast in concrete or masonry shall be headed bolts with cut threads conforming to ASTM F1554 grade 36, 55 or 105 as indicated on drawings.
- F. Machine Bolts: ASTM A307.
- G. High Strength Bolts, Nuts and Washers: Install in accordance with requirements for A325 and A490 slip critical and snug tight conditions as indicated on drawings. Install high strength bolts with snug tight type connections with threads included in shear plane except as otherwise noted. Install hardened washers in conformance with AISC Specifications.
 1. Bolt Specifications: Bolts shall conform to the requirements of the current edition of the Specifications of the American Society for Testing and Materials for High-Strength Bolts for Structural Steel Joints, ASTM A325, Heat Treated Steel Structural Bolts, 150 ksi Minimum Tensile Strength, ASTM A490 as indicated on drawings.
 2. Bolt Geometry: Bolt dimensions shall conform to the current requirements of the American National Standards Institute for Heavy Hex Structural Bolts, ANSI Standard B18.2.1. The length of bolts shall be such that the end of the bolt will be flush with or outside the face of the nut when properly installed.
 3. Nut Specifications: Nuts shall conform to the current chemical and mechanical requirements of the American Society for Testing and Materials Standard Specification for Carbon and Alloy Steel Nuts, ASTM

A563, Appendix Table X1.1. Provide grade A Heavy Hex nuts for grade 36 threaded rods. Use grade C, Heavy Hex nuts for grade 55 and 105 threaded rod.....

4. Washers: Flat circular washers and square or rectangular beveled washers shall conform to the current requirements of the American Society for Testing and Materials Standard Specification for Hardened Steel Washers, ASTM F436.
 5. Tension Control Fastener System: Bolts shall conform to the requirements of the current edition of the Specifications of the American Society for Testing and Materials for Twist Off Type Tension Control Structural Bolt/Nut/Washer Assemblies, ASTM F1852, providing equivalent properties to ASTM A325 or A490 as indicated on drawings.
- H. Headed Stud-Type Shear Connectors: ASTM A108 Grade 1015 or 1020 Cold-finished carbon steel with dimensions complying with AISC Specifications.
1. Tensile strength, 60,000 psi.
 2. Elongation in 2 inches, 20 percent
 3. Reduction of area, 50 percent.
- I. Provide hexagonal heads and nuts for all connections per ASTM A563, Appendix Table X1.1.
- J. Electrodes for Welding: Comply with AWS Code, E70 Series minimum. Fabricator to select proper electrodes according to weld procedures as submitted.
- K. Shop Primer:
- L. Powder Driven Fasteners:
- M. Expansion Bolts:
- 1.04 SOURCE QUALITY CONTROL
- A. Provide mill certificates or test.
- 1.05 FIELD QUALITY CONTROL
- A. Testing Agency: State employed.

END OF SECTION

SECTION 05500 - METAL FABRICATIONS

PART 1 - GENERAL

1.01 SUMMARY

A. METAL FABRICATIONS:

1. Loose bearing and leveling plates, galvanized.
2. Loose steel lintels, galvanized.
3. Shelf angles, galvanized.
4. Steel framing and supports for overhead, countertops, mechanical and electrical equipment.
5. Steel pipe columns for supporting wood frame construction.
6. Prefabricated building columns.
7. Metal angle corner guards.
8. Metal edgings.
9. Miscellaneous metal trim.
10. Pipe guards, galvanized.
11. Wheel guards.
12. Pipe bollards, Schedule 80 steel.

1.02 MATERIALS

- A. Materials: Steel angles, Steel tubing, Steel pipe, Iron castings, Aluminum.
- B. Miscellaneous Framing and Supports: Galvanize exterior and interior locations.
- C. Miscellaneous Steel Trim: Galvanize exterior and interior locations.

END OF SECTION

SECTION 05521 - PIPE AND TUBE RAILINGS

PART 1 - GENERAL

1.01 SUMMARY

- A. Steel pipe and tube handrails and railing systems attached to walls with brackets.

1.02 QUALITY ASSURANCE

- A. Fabricator to engineer and fabricate handrails and railing systems to withstand design loads.

1.03 MATERIALS

- A. Steel: Galvanized.

1.04 FABRICATION

- A. Changes in Direction of Members: As detailed by flush radius bends.
- B. Connections: Welded.
- C. Toe boards.
- D. Finishes:
 - 1. Steel: galvanized with shop primer.

END OF SECTION

SECTION 06101 - ROUGH CARPENTRY

PART 1 - GENERAL

1.01 SUMMARY

- A. Framing with dimension lumber and engineered wood products.
- B. Wood furring, grounds, nailers and blocking.
- C. Sheathing.

1.02 MATERIALS

- A. Wood Treatment: Preservative.
- B. Framing:
 - 1. Non-Load-Bearing Interior partitions: Dimension lumber.
 - 2. Load-Bearing Walls: Dimension lumber.
- C. Engineered Wood Products: Prefabricated wood I-joists.
- D. Concealed, Performance-Rated Structural-Use Panels: Combination subfloor-underlayment, wall sheathing, roof sheathing.
- E. Plywood backing panels for electrical, telephone equipment.
- F. Air-Infiltration Barrier; Polyolefin air retarder.
- G. Metal Framing anchors: joist hangers, post bases, joist ties, hold downs.
- H. Sill-sealer gaskets.

1.03 INSTALLATION

- A. Exterior Wall Framing: 2x6 studs at 16 inches o.c.
- B. Interior Wall Framing: 2x4 studs at 16 inches o.c.
- C. Roof Framing: Engineered trusses at 24 inches o.c.
- D. Floor Framing: 16 inches o.c.

END OF SECTION

SECTION 06170 - PREFABRICATED STRUCTURAL WOOD

PART 1 - GENERAL

1.01 SUMMARY

- A. All lumber used for truss members shall conform to the published stress ratings for the species and grades as designed. All members shall be cut from stock which bears the proper grade-mark stamp of a recognized grading association, or licensed lumber inspection laboratory.
 - 1. Moisture content shall not exceed 19% nor be less than 7% at time of truss fabrication, and shall conform to reference specifications.
 - 2. Connectors shall be manufactured from prime commercial quality galvanized sheet metal of not less than 20 gauge thickness with minimum yield strength of 33,000 psi and minimum ultimate tensile strength of 48,000 psi.
 - 3. The trusses shall be custom designed to fit the dimensions and loads and deflection requirements indicated on the drawings. All designs shall be in accordance with the requirements of California Building Code, latest adopted edition.

END OF SECTION

SECTION 06180 - GLUE LAMINATED BEAMS

PART 1 - GENERAL

1.01 SUMMARY

- A. Beams, girders and purlins.

1.02 QUALITY ASSURANCE

- A. Members designed by engineer of record.

1.03 MATERIALS

- A. Structural Glued-Laminated Units:
 - 1. Lumber Species: Douglas fir.
 - 2. Appearance Grade: Architectural.
 - 3. Treatment: Seal coat.
- B. Factory finishing.

END OF SECTION

SECTION 06190 - FABRICATED WOOD TRUSSES

PART 1 - GENERAL

1.01 SUMMARY

- A. Roof Trusses:
 - 1. Triangular pitched.
 - 2. Parallel-chord, top-chord bearing.

1.02 QUALITY ASSURANCE

- A. Fabricator to engineer, fabricate and erect trusses to withstand design loads.
- B. Requirements: TPI.

1.03 MATERIALS

- A. Dimension Lumber:
 - 1. Grade for Chord Members: No. 1.
 - 2. Grade for Web Members: Same as chords.
 - 3. Species: Douglas Fir.
- B. Metal Connector Plates: Electrolytic zinc-coated steel.
- C. Metal Framing Anchors: Galvanized steel.

1.04 INSTALLATION

- A. Truss Spacing: 24 inches o.c.

END OF SECTION

SECTION 06200 - FINISH CARPENTRY

PART 1 - GENERAL

1.01 SUMMARY

- A. Framing with dimension lumber.
- B. Wood blocking and backing.
- C. Sheathing.
- D. Subflooring.
- E. Interior wood trim.

1.02 MATERIALS

- A. Wood Treatment: Preservative.
- B. Framing: Interior partitions.
- C. Boards: Concealed.
- D. Interior Wood Trim: softwood Hardwood.
- E. Plywood backing panels for electrical and telephone equipment.

1.03 INSTALLATION

- A. All equipment, handrails, grab bars and etc. shall have backing installed.

END OF SECTION

SECTION 06410 - CUSTOM CASEWORK

PART 1 - GENERAL

1.01 SUMMARY

- A. Related Documents.
- B. Description of requirements for materials, fabrications and installation of casework, and accessory items as shown on Drawings and necessary to complete the Work.
 - 1. Plastic Laminated and wood cabinets.
 - 2. Plastic laminated countertops and back splashes.
 - 3. Custom casework.
 - 4. Preparation for installation of utilities.
 - 5. Casework grade to be Custom WIC unless specified otherwise.
 - 6. Provide all required cabinet hardware.
- C. Related Sections:
 - 1. Section 06100: Rough Carpentry (Blocking)
 - 2. Section 06200: Finish Carpentry
 - 3. Section 09260: Gypsum Wallboard Systems.
 - 4. Section 09650: Resilient Floor Tile.
 - 5. Section 09900: Painting (Painter applied primer and finish work).
 - 6. Division 15: Plumbing/ Mechanical
 - 7. Division 16: Electrical

1.02 QUALITY ASSURANCE

- A. References and Standards:
- B. Fabricator and Installer Qualifications.
- C. Installation Acceptance.

1.03 SUBMITTALS (Submit under provision of Section 01300)

- A. Shop Drawings: Drawings shall show each of the items to be provided under this Section including: materials, profiles and elevations, assembly methods, fastening

methods, accessory listings, hardware types and locations, schedule of finishes, completely detailing joinery, including D.S.A. approved anchorage.

B. Certification:

C. Samples:

1.04 PRODUCT DELIVERY, STORAGE AND HANDLING

A. Delivery.

B. Storage and Handling:

1.05 JOB CONDITIONS

A. Environmental Requirements:

PART 2 - MATERIALS

2.01 MATERIALS AND CONSTRUCTION GRADE

A. Materials and Construction Grades:

B. Base Material for Plastic Laminate:

C. Fasteners:

D. Miscellaneous/Casework Items:

2.02 FABRICATION - GENERAL

A. General:

B. Plastic Laminate Covered Casework:

C. Shelving.

D. Drawers and Flat Files:

E. Casework Bases.

2.03 FABRICATION - GENERAL CASES AND COUNTER TOPS

2.04 HARDWARE

A. General Requirements.

B. Hardware Installation:

2.05 MISCELLANEOUS

HAMMIL VALLEY ES STATION
MONO COUNTY, CALIFORNIA
DEPT. OF PUBLIC WORKS

BUDGET PACKAGE PHASE
OUTLINE SPECIFICATIONS

2.06 SOURCE QUALITY CONTROL

2.07 SAFE LOCATION

PART 3 - EXECUTION

3.01 CONDITION OF SURFACES

3.02 INSTALLATION

3.03 FINAL INSPECTION:

3.04 CLEANING AND ADJUSTING

END OF SECTION

SECTION 07210 - INSULATION

PART 1 - GENERAL

1.01 SUMMARY

- A. Insulation Applications:
 - 1. Cavity wall insulation.
 - 2. Concealed building insulation.
 - 3. Exposed building insulation.
 - 4. Loose-fill building insulation.
- B. Radiant barriers.
- C. Safing insulation for fire containment.

1.02 MATERIALS

- A. Insulation.
 - 1. Cellular glass.
 - 2. Unfaced fiberglass blanket.
 - 3. Faced fiberglass blanket.
 - 4. Unfaced mineral-fiber blanket.
 - 5. Faced mineral-fiber blanket.
 - 6. Glass-fiber loose-fill.
- B. Radiant Barriers: Foil-polymer laminate.
- C. Vapor Retarders: Polyethylene and Reinforced-polyethylene.
- D. Protection board.
- E. Eave ventilation troughs.

END OF SECTION

SECTION 07270 - FIRESTOPPING

PART 1 - GENERAL

1.01 SUMMARY

- A. 3M Company moldable putty firestop and USG Thermafiber safing insulation.

END OF SECTION

SECTION 07420 – INSULATED METAL WALL PANELS

PART 1 - GENERAL

1.01 DESCRIPTION

- A. Requirements for materials, fabrications and installation of prefinished insulated metal wall panels and associated accessory items.

1.01 RELATED WORK SPECIFIED ELSEWHERE

- A. The requirements of Division 1 apply to the Work of this Section.
- B. Section 05210: Structural Steel
- C. Section 06101: Rough Carpentry.
- D. Section 07620: Flashing and Sheet Metal.

1.02 QUALITY ASSURANCE

1.03 SUBMITTALS

PART 2 - PRODUCTS

2.01 MATERIALS

- A. Preformed insulated 24 gauge metal wall panels. Panel thickness to achieve R-19 insulation value.
- B. Flashings and Trims: Factory finished to match panels, provided by roofing manufacturer, pre-shaped and ready to install per plans.
- C. Fasteners
- D. End closures
- E. Sealant
- F. Sealant Tape

PART 3 - EXECUTION

3.01 INSPECTION:

3.02 INSTALLATION

END OF SECTION

SECTION 07460 – SIDING

PART 1 – GENERAL

1.01 GENERAL

- A. Fiber cement siding panels, plank, fascia, moulding and accessories.

1.02 RELATED SECTIONS

- A. Section 06101: Rough Carpentry.
- B. Section 07210: Insulation.

1.03 SUBMITTALS

1.04 QUALITY ASSURANCE

- A. Installer Qualifications: Minimum of 2 years experience with installation of similar products.
- B. Mock-Up: Provide a mock-up for evaluation of surface preparation techniques and application workmanship.
 - 1. Finish areas designated by Architect.
 - 2. Do not proceed with remaining work until workmanship, color and sheen are approved by Architect.
 - 3. Refinish mock-up area as required to produce acceptable work.

1.05 DELIVERY, STORAGE AND HANDLING

1.06 PROJECT CONDITIONS

1.07 WARRANTY

- A. Product Warranty: Limited product warranty against manufacturing defects.
 - 1. Hardipanel vertical siding for 50 years.
 - 2. Hardie Trim for 10 years.
- B. Workmanship Warranty: Application limited warranty for 2 years.

PART 2 – PRODUCTS

2.01 MANUFACTURERS

- A. Acceptable Manufacturer: James Hardie Building Products, Inc; 26300 La Alameda, Suite 250, Mission Viejo, CA 92691. ASD. Toll Free Residential: (888) J-HARDIE. Toll Free Commercial: (866) 274-3464. Tel: (949) 348-1800. Fax: (949) 367-0185. or equal

2.02 SIDING

- A. Code Compliance Requirement for Materials:
1. National Evaluation Report #NER 405 (BOCA, ICBO, SBCCI).
 2. City of Los Angeles, Research Report #24862.
 3. Metro Dade County, Florida Acceptance #07-0148, 04.
 4. US Department of Housing and Urban Development Materials Release 1263d.
 5. California DSA PA-019.
 6. City of New York M EA 223-93-M.
 7. Non-asbestos fiber-cement siding where required to be non-combustible shall be tested in accordance with ASTM E136.
- B. Vertical Siding: Hardiepanel as manufactured by James Hardie Building Products, Inc.
1. Type: Sierra 8 inches (203 mm) Vertical siding panel 4 feet by 8 feet (1219 mm by 2438 mm).
- C. Plank Siding: Hardieplank as manufactured by James Hardie Building Products, Inc.
1. Type: Select Cedarmill with four inch exposure.
- D. Trim: Hardietrim Fascia and Moulding as manufactured by James Hardie Building Products, Inc. Select Cedarmill 7/16 boards, 4" wide.

2.03 FASTENERS

- A. Wood Framing Fasteners:
1. Wood framing: 4d common corrosion resistant nails.
 2. Wood framing: 6d common corrosion resistant nails.
 3. Wood framing: 0.089 inch (2.2 mm) shank by 0.221 inch (5.6 mm) head by 2 inches (51 mm) corrosion resistant siding nails.
 4. Wood framing: 0.089 inch (2.4 mm) shank by 0.222 inch (5.6 mm) head by 2 inches (51 mm) corrosion resistant siding nails.
 5. Wood framing: 0.089 inch (2.3 mm) shank by 0.221 inch (5.6 mm) head by 1-1/2 inches (38 mm) corrosion resistant siding nails.
 6. Wood framing: 0.089 inch (2.3 mm) shank by 0.225 inch (5.7 mm) head by 1-1/2 inches (38 mm) corrosion resistant siding nails.
 7. Wood framing: 0.089 inch (3 mm) shank by 0.371 inch (9.4 mm) head by 1-1/4 inches (32 mm) corrosion resistant roofing nails.
 8. Wood framing: 1-1/4 inches (32 mm) corrosion resistant roofing nails.
 9. Wood framing: 1-1/2 inches (38 mm) corrosion resistant roofing nails.
- B. Metal Framing:
1. Metal framing: 1-1/4 inches (32 mm) No. 8-18 by 0.375 inch (9.5mm) head self-drilling, corrosion resistant S-12 ribbed buglehead screws.
 2. Metal framing: 1-5/8 inches (41 mm) No. 8-18 by 0.323 inch (8.2 mm) head self-drilling, corrosion resistant S-12 ribbed buglehead screws.

3. Metal framing: 1 inch (25 mm) No. 8-18 by 0.323 inch (8.2 mm) head self-drilling, corrosion resistant ribbed buglehead screws.
4. Metal framing: 1 inch (25 mm) No. 8-18 by 0.311 inch (7.9 mm) head self-drilling, corrosion resistant S-12 ribbed buglehead screws.
5. Metal framing: 1.5 inch (38 mm) (AGS-100) .100 inches by 25 inches (2540 mm by 635 mm) ET&F Pin or equivalent pneumatic fastener.
6. Concrete Walls: Erica Stud Nail, ET&F ASM No. 144-125, 0.14 inch (3.6 mm) shank by 0.30 inch (7.6 mm) head by 2 inches (51 mm) corrosion resistant nail.

2.04 FINISHES

- A. Factory Primer: Provide factory applied universal primer.
 1. Primer: PrimePlus by James Hardie.
 2. Topcoat: Refer to Section 09900 and Exterior Finish Schedule.

PART 3 – EXECUTION

3.01 EXAMINATION

3.02 PREPARATION

3.03 INSTALLATION

3.05 FINISHING

3.06 PROTECTION

END OF SECTION

SECTION 07610 - METAL ROOFING

PART 1 - GENERAL

1.01 SUMMARY

- A. Standing seam Metal Roofing System, minimum of 24 gauge steel conforming to ASTM A446 Grade A or higher. Finish paint system to be Polyvinyl Fluorocarbon. Color to be selected by Architect. (BHP, AEP, or equal).

END OF SECTION

SECTION 07620 - SHEET METAL FLASHING AND TRIM

PART 1 - GENERAL

1.01 SUMMARY

A. Flashing and Trim:

1. Concealed through-wall metal flashing.
2. Reglets.
3. Gutters.
4. Downspouts.
9. Base flashing.
10. Counterflashing.
11. Flashing receivers.
12. Valley flashing.
13. Drip edges.
14. Eave flashing.
16. Roof-penetration flashing.
17. Shower pans.
18. Overhead-piping safety pans.

1.02 QUALITY ASSURANCE

- A. Mockups for sheet metal fabrications.
- B. Standards: SMACNA.

1.03 MATERIALS

A. Metals:

1. Galvanized steel.

END OF SECTION

SECTION 07920 - JOINT SEALERS

PART 1 - GENERAL

1.01 SUMMARY

A. Exterior Joints in Vertical Surfaces and Non-traffic Horizontal Surfaces:

1. Between metal trim surfaces and joints.
2. Perimeter joints between materials listed above and frames of doors and windows.
3. Control and expansion joints in ceiling and overhead surfaces.
4. Between wood to metal and wood to wood joints.
5. Insulated wall panels

B. Exterior Joints in Horizontal Traffic Surfaces:

1. Control, expansion, and isolation joints in cast-in -place concrete slabs.

C. Interior Joints in Vertical surfaces and Horizontal Non-traffic Surfaces:

1. Control and expansion joints on exposed interior surfaces of exterior walls.
2. Perimeter joints of exterior openings.
3. Tile control and expansion joints.
4. Perimeter joints between interior wall surfaces and frames of interior doors and windows.
5. Perimeter joints between interior wall surfaces and exposed wood supports.
6. Between plumbing fixtures and adjoining walls, floors and counters.

1.02 QUALITY ASSURANCE

- A. Preconstruction compatibility and adhesion testing.
- B. Product testing.
- C. Preconstruction field-adhesion testing.
- D. Mockups.

1.03 WARRANTY

- A. Installer: Two years.
- B. Manufacturer: 20 years.

1.04 MATERIALS

- A. Elastomeric Sealants: Urethane Compounds, silicone Rubber and Polysulfide Rubber.
- B. Solvent-Release Sealants: Acrylic, Pigmented narrow joint.
- C. Latex sealants.
- D. Butyl-based tape sealant.
- E. Preformed Sealants: Silicone sealant system.
- F. Joint Sealant Backing: Elastomeric tubing.

END OF SECTION

SECTION 08110 - METAL DOORS AND FRAMES

PART 1 - GENERAL

1.01 SUMMARY

- A. Exterior steel doors.
- B. Interior and exterior steel frames placed in masonry and gypsum board assemblies.

1.02 QUALITY ASSURANCE

- A. Requirements: ANSI/SDI 100.

1.03 MATERIALS

- A. Exterior Doors:
 - 1. Grade: Extra heavy duty, insulated.
 - 2. Design: Full flush.
 - 3. Materials: Galvanized steel.
- B. Door Louvers: Sight proof with insect screen.
- C. Frames:
 - 1. Construction: Welded for exterior, knocked down for interior.
 - 2. Material: Galvanized steel.
- D. Assemblies: Thermal rated.
- E. Finishes: Factory prime for field painting.

END OF SECTION

SECTION 08211 - FLUSH WOOD DOORS

PART 1 - GENERAL

1.01 SUMMARY

- A. Solid-core doors with Birch wood-veneer faces.
- B. Job-fit doors to frames.
- C. Factory machining for hardware.
- D. Light frames.

1.02 QUALITY ASSURANCE

- A. Quality Standard: NWWDA.

1.03 WARRANTY

- A. Materials and Workmanship:
 - 1. Solid-Core Interior Doors: Life of installation.

1.04 MATERIALS

- A. Doors for Opaque Finish:
 - 1. Grade: Premium.
 - 2. Faces: Hardboard for interior doors.
- B. Interior Hardboard-Faced, Solid-Core Doors:
 - 1. Core: Particleboard.
 - 2. Construction: Bonded core.
- C. Louvers: Galvanized steel.
- D. Light Opening Frames: Wood.
- E. Finish: Shop prime.

END OF SECTION

SECTION 08305 - ACCESS DOORS

PART 1 - GENERAL

1.01 SUMMARY

- A. Wall access doors.
- B. Ceiling access doors.

1.02 MATERIALS

- A. Insulated doors: Material: Stainless steel.
- B. Non-insulated, Doors: Stainless steel, One hour for walls.
- C. Flush Doors with Exposed Trim Doors: Stainless steel.
- D. Trimless, Flush Doors for Gypsum Board Doors: Stainless steel.
- E. Locks: Key-operated cylinder lock.

END OF SECTION

SECTION 08331 - OVERHEAD COILING DOORS

PART 1 - GENERAL

1.01 SUMMARY

- A. Overhead Coiling Doors:
 - 1. Insulated service doors.

1.02 QUALITY ASSURANCE

- A. Performance Requirements:
 - 1. Wind Load: 20 lbf/sq. ft.
 - 2. Cycles: Designed for not less than 20,000 cycles.

1.03 MATERIALS

- A. Door Curtain: Hot-dipped galvanized steel with view lights.
- B. Polystyrene or polyurethane-foam insulation with hot-dipped galvanized inside curtain face.
- C. Seals: Weather.
- D. Counterbalancing mechanism enclosed in hood.
- E. Finishes:
 - 1. Steel and Galvanized Steel: Factory fluoropolymer powder-coat-applied finish.
- F. Manual Door Operators: Chain hoist.
- G. Electric motor operation: Remote-control station with obstruction detection device and radio control.

END OF SECTION

GARDEN VALLEY FIRE STATION
FACILITY REPLACEMENT
EL DORADO COUNTY, CALIFORNIA
DEPT. OF GENERAL SERVICES AND CAL FIRE

BUDGET PACKAGE PHASE
OUTLINE SPECIFICATIONS

SECTION 08500 - VINYL WINDOWS

PART 1 - GENERAL

1.01 SUMMARY

- A. Exterior windows shall be premium vinyl type operable and fixed, clear double glazed low 'e' type, complete with screens, Jeld-Wen Window Systems, as noted, or approved equal.

END OF SECTION

SECTION 08710 - DOOR HARDWARE

PART 1 - GENERAL

1.01 SUMMARY

- A. Door hardware required for swinging and folding doors.

1.02 SUBMITTALS

- A. Final hardware and keying schedules.

1.03 QUALITY ASSURANCE

- A. Standard: ANSI/BHMA.

1.04 MATERIALS

- A. Hinges.
- B. Lock Cylinders and keys:
 - 1. System: Multiple building.
 - 2. Cylinders: Interchangeable-core inserts.
- C. Key control system.
- D. Locks, latch sets and bolts.
- E. Exit devices.
- F. Closers and Holders: Combination closer and holder.
- G. Door Trim Units and Protection Plates: Stainles.
- H. Bifold Door Equipment: Extra-heavy duty.
- I. Weatherstripping for exterior doors.
- J. Sound stripping for interior doors.
- K. Door bottom seals.
- L. Thresholds.
- M. Finishes: Satin stainless steel.

END OF SECTION

SECTION 08800 - GLAZING

PART 1 - GENERAL

1.01 SUMMARY

- A. Glazing required for the following:
 - 1. Windows.
 - 2. Doors.

1.02 QUALITY ASSURANCE

- A. Mockups for each glass product.
- B. Pre-construction adhesion and compatibility testing.

1.03 WARRANTY

- A. Deteriorated Coated Glass: Not less than 10 years.
- B. Deteriorated Laminated Glass: Not less than five years.
- C. Deteriorated Insulating Glass: Not less than 10 years.

1.04 MATERIALS

- A. Dual-pane insulated float glass: Clear.
- B. Dual-pane tempered insulated float glass: Clear.
- C. Dual-pane insulated obscure glass.
- D. Insulating Glass: Aluminum.
- E. Elastomeric glazing sealants.
- F. Glazing Tapes: Back-bedding mastic type.
- G. Glazing Gaskets: Lock strip.

END OF SECTION

SECTION 09255 - GYPSUM BOARD ASSEMBLIES

PART 1 - GENERAL

1.01 SUMMARY

- A. Gypsum board assemblies attached to wood framing and adhesively bonded to interior concrete and masonry substrates.
- B. Cementitious backer board at wood burning stove installed with gypsum board assemblies.
- C. Water-resistant gypsum backing board installed with gypsum board assemblies.
- D. Metal accessories.

1.02 QUALITY ASSURANCE

- A. Mockups to demonstrate finishes.

1.03 MATERIALS

- A. Gypsum Wallboard: Regular 5/8 inch.
- B. Water-Resistant Gypsum Backing Board: Regular: 5/8 inch.
- C. Cementitious Backing Board: Regular, 1/2 inch.
- D. Accessories: Cornerbeads, LC-beads, L-beads, U-beads, one-piece control joints.
- E. Joint Reinforcing: Glass-fiber fabric.
- F. Joint Compounds: Drying type.
- G. Acoustical sealants.
- H. Sound attenuation blankets.
- I. Texture Finish: Smooth at Kitchen and Restrooms; light orange peel elsewhere.

1.04 INSTALLATION

- A. Fasten gypsum board to supports with screws.
- B. Finish: In accordance with GA-214 for each affected surface and type of application.

END OF SECTION

SECTION 09311 - CERAMIC TILE

PART 1 - GENERAL

1.01 SUMMARY

- A. Tile for Mortar Set Installation:
 - 1. Unglazed ceramic mosaic.
 - 2. Glazed wall.
- B. Waterproof membrane for thin-set tile installations.
- C. Stone thresholds.
- D. Floor Substrates: Concrete.
- E. Wall Substrates: Wood.

1.02 QUALITY ASSURANCE

- A. Mockups for each form of construction.

1.03 MATERIALS

- A. Trim Shapes: Coved base, Bullnose cap and Surface bullnose.
- B. Stone Thresholds: Marble.
- C. Waterproofing: PVC sheet.
- D. Asphalt-felt cleavage membrane.
- E. Expanded metal lath: Self furring.
- F. Mortar:
 - 1. Latex-portland cement.
- G. Organic adhesive.
- H. Grout:
 - 1. Latex-portland cement.
- I. Elastomeric Sealants: One-part, mildew-resistant.

END OF SECTION

SECTION 09650 - RESILIENT FLOORING

PART 1 - GENERAL

1.01 SUMMARY

- A. Related Documents: Drawings and General Provisions of Contract, including General and Supplementary Conditions and Division 1 Specification Section apply to Work of this Section as if printed herein.
- B. Section Includes: Description of the requirements for materials and installation of resilient floor tile, sheet vinyl, base and associated accessory items, as indicated on Drawings and necessary to complete the Work.
 - 1. Vinyl Composition Tile (VCT)
 - 2. Sheet Vinyl Flooring
 - 3. Rubber Base Materials
- C. Related Sections:
 - 1. Section 03300: Cast-in-Place Concrete (Floor Substrate)
 - 2. Section 09260: Gypsum Wallboard and Cement Board Finishes
 - 3. Section 09300: Ceramic Tile
 - 4. Section 09680: Carpet

1.02 REFERENCES

- A. ASTM F1066 – Vinyl Composition Floor Tile
- B. ASTM F1303 – Sheet Vinyl Floor Coverings with Backing
- C. ASTM F1861 – Resilient Rubber Base
- D. ASTM F970 – Static Load Test
- E. ASTM F710 – Preparation of Concrete Floors.

1.03 QUALITY ASSURANCE

- A. Standard of Manufacture.
- B. Installer Qualifications.

1.04 SUBMITTALS (Submit under the provisions of Section 01300)

- A. Manufacturer's Data.
- B. Samples.
- C. Maintenance Data and Instructions.
- D. Maintenance Materials.

1.05 PRODUCT DELIVERY AND STORAGE

1.06 ENVIRONMENTAL REQUIREMENTS

1.07 JOB CONDITIONS

1.08 WARRANTY

- A. The warranty for work under this Section shall be extended for a period of two (2) years against defects in materials, installation and workmanship, and shall include unconditional guaranty against loss of bond of resilient floor covering and base for this period.

PART 2 - PRODUCTS

2.01 MATERIALS

- A. Vinyl Composition Tile Flooring.
 - 1. Manufacturers
- B. Sheet vinyl Flooring
 - 1. Manufacturers
- C. Resilient Base.
- D. Reducing Strips.
- E. Underlayment and Crack Filler.
- F. Adhesive, Primers, and Cleaning Materials.

PART 3 - EXECUTION

3.01 EXAMINATION AND PREPARATION

- A. Examine all surfaces to receive specified work herein.
- B. Condition of Surfaces.

3.02 ADHESIVE APPLICATION

3.03 INSTALLATION

3.04 CLEANING AND PROTECTION

END OF SECTION

SECTION 09680 - CARPET - GLUE DOWN

PART 1 - GENERAL

1.01 SUMMARY

- A. Carpet.
- B. Substrate: Concrete.

1.02 SUBMITTALS

- A. Schedule of carpet for each room.

1.03 QUALITY ASSURANCE

- A. Carpet meeting flame-spread and smoke-developed requirements.
- B. Carpet meeting critical radiant flux Class I classification requirements.
- C. Mockups for each type of carpet and installation method.

1.04 WARRANTY

- A. Carpet Materials and Workmanship: Five years.

1.05 MATERIALS

- A. Carpet:
 - 1. Construction: Tufted.
 - 2. Face Construction: Level-loop pile.
 - 3. Face Fiber: Nylon

1.06 INSTALLATION

- A. Installation Method: Direct glue-down.

END OF SECTION

SECTION 09900 - PAINTING

PART 1 - GENERAL

1.01 SUMMARY

- A. Surface preparation and field painting of exposed exterior and interior items and surfaces.
- B. Substrates: Cementitious materials, Wood, Ferrous metals, Nonferrous metals and Gypsum board.

1.02 QUALITY ASSURANCE

- A. Benchmark samples (mockups) for each type of coating and substrate to establish required sheen, color, and texture.

1.03 FIELD QUALITY CONTROL

1.04 EXTERIOR PAINT SCHEDULE

- A. Concrete:
 - 1. Full-Gloss, Acrylic Enamel: Two coats over primer.
- B. Concrete Masonry Units:
 - 1. Full-Gloss, Acrylic Enamel: Two coats over block filler and primer.
- C. Smooth Wood:
 - 1. Full-gloss, Acrylic enamel: Two coats over primer.
- D. Wood Trim:
 - 1. Medium-shade, Full-gloss, Acrylic Enamel: Two coats over primer.
 - 1. Deep-Color, Full-gloss, Acrylic Enamel: Two coats over primer.
- E. Plywood:
 - 1. Full-Gloss, Acrylic Enamel: Two coats over primer.
- F. Ferrous Metal:
 - 1. Full-gloss Acrylic Enamel: Two coats over rust-inhibitive primer.
- G. Zinc-coated metal:
 - 1. Full-Gloss, Acrylic Enamel: Two coats over galvanized metal primer.

H. Cement board siding:

1. Full-gloss, Acrylic enamel: Two coats over primer.

1.05 INTERIOR PAINT SCHEDULE

A. Concrete Masonry Units:

1. Full-Gloss, Acrylic Enamel: Two coats over block filler and primer.

B. Gypsum Board:

1. Full-Gloss, Acrylic Enamel: Two coats over primer.

C. Woodwork and Hardboard:

1. Full-Gloss, Acrylic enamel: Two coats over wood undercoater.

D. Ferrous Metal:

1. Full-Gloss, Acrylic Enamel: Two coats over primer.

E. Zinc-Coated Metal:

1. Full-gloss Acrylic Enamel: Two coats over primer.

END OF SECTION

SECTION 09960 - FIBERGLASS WALL PANEL

PART 1 - GENERAL

1.01 SUMMARY

- A. Fiberglass reinforced polyester panel with plastic moulding shall be Marlite FRP pebble grained panels as manufactured by Marlite or approved equal. Flame spread 25, smoke developed 180. Adhesive shall be per manufacturer's recommendations, color as selected by the Architect.

END OF SECTION

SECTION 10105 - VISUAL DISPLAY BOARDS

PART 1 - GENERAL

1.01 SUMMARY

- A. Marker boards: Claridge Series 4, Type A, liquid chalk surface of porcelain enamel coated steel backed by hardboard, with chalk trough and map rail.
- B. Tackboard: Claridge #1381-FREW, vinyl covered Fir-tex tackboard.
- C. Provide divider bars, trim, chalk troughs, marker and eraser kits, cleaner, etc. for complete functional systems.

END OF SECTION

SECTION 10210 - ARCHITECTURAL LOUVERS

PART 1 - GENERAL

1.01 SUMMARY

- A. Fixed formed-metal louvers.

1.02 QUALITY ASSURANCE

- A. Standard: SMACNA's "Architectural Sheet Metal Manual".

1.03 PRODUCTS

- A. Fixed, Formed-Metal Louvers:
 - 1. Horizontal: Nondrainable blade.
 - 2. Material: Galvanized steel sheet.
- B. Insect wire screening.

1.04 FINISHES

- A. Galvanized Steel: Factory primed for field painting.

END OF SECTION

SECTION 10350 - FLAGPOLES

PART 1 - GENERAL

1.01 SUMMARY

- A. Steel flagpole.

1.02 SUBMITTALS

- A. Structural calculations showing compliance with design loadings.

1.03 QUALITY ASSURANCE

- A. Structural Performance: Basic wind speed 100 mph.

1.04 MATERIALS

- A. Anodized aluminum: Cone tapered, with shop applied double coat fluoropolymer resin coating finish.
 - 1. Mounting: Baseplate.
- B. Fittings: Finial ball, internal halyard, winch system with halyard flag snaps.

END OF SECTION

SECTION 10400 - IDENTIFYING DEVICES

PART 1 - GENERAL

1.01 SUMMARY

- A. Restroom signage
- B. Building signage
- B. Monument sign
- C. Exterior Site signs

1.02 PRODUCTS

- A. Restroom and building signage:
 - 1. Material: Acrylic plastic.
 - 2. Copy Process: Routed lettering, raised Braille
 - 3. Matte finish, lettering to contrast with background
- B. Monument Sign:
 - 1. Concrete with cast in place lettering and county logo plaque.
- C. Exterior Site Signs:
 - 1. Porcelain finish on aluminum. Posts shall be galvanized steel in concrete foundation.

1.03 INSTALLATION

- A. Mounting: Factory applied pressure sensitive adhesive covering the entire back side that will adhere firmly to mounting surface.

END OF SECTION

SECTION 10500 - LOCKERS

PART 1 - GENERAL

1.01 SUMMARY

- A. Description: Provide open front metal equipment lockers,
- B. Related Work Specified Elsewhere:
 - 1. Section 03300 - Concrete
 - 2. Section 06100 - Rough Carpentry
 - 3. Section 06200 - Finish Carpentry

1.02 QUALITY ASSURANCE

- A. Manufacturing Standard.
- B. Fabricator Qualifications.
- C. Installer Qualifications.

1.03 SUBMITTALS

- A. Shop Drawings: Submit manufacturing and installation details, including fastenings, for review prior to fabrication of work.
- B. Samples: Submit the following listed samples for review prior to fabrication of work.
- C. Product Data.

1.04 PRODUCT HANDLING

- A. General.
- B. Delivery.
- C. Storage.

1.05 GUARANTEE

- A. GUARANTEE-WARRANTY: Submit upon completion of the work, in the form prescribed under Section 01600 - Warrantees, covering all defects in materials and workmanship excluding finish, damage resulting from deliberate destruction and vandalism under this Section for a period of 10 years from the date of final acceptance by the Owner.

PART 2 - PRODUCTS

2.01 MATERIAL

- A. Available Manufacturers.
- B. Steel.
- C. Fasteners.
- D. Hardware.

2.02 FABRICATION

- D. Frame Vertical Panels.
- E. Integral Frame Locker Base.
- L. Shelves and Horizontal Dividers/Bottoms.
- M. Backs.
- M. Locker Accessories:
 - 1. Locks:
 - 3. Number Plates.
 - 4. Finished End Panels.
 - 6. Filler panels, false fronts and trim.

PART 3 - EXECUTION

3.01 EXAMINATION OF CONDITIONS

- A. Conditions of the Workplace.
- B. Job Measurements.

3.02 INSTALLATION:

- A. Placement.
- B. Anchorage.
- C. Trim.

3.03 ADJUSTMENTS AND MAINTENANCE:

- A. GENERAL: Prior to occupancy of the building, all moveable parts shall be properly adjusted to assure smooth operation.

3.04 CLEANING:

- A. GENERAL.

END OF SECTION

SECTION 10522 - FIRE EXTINGUISHERS, CABINETS AND ACCESSORIES

PART 1 - GENERAL

1.01 SUMMARY

- A. Portable fire extinguishers.
- B. Fire-Protection Cabinets:
 - 1. Fire extinguisher.
- C. Accessories.

1.02 QUALITY ASSURANCE

- A. Fire Extinguishers: NFPA 10.
 - 1. UL Rating: 2A-10B:C.

1.03 MATERIALS

- A. Portable Fire Extinguishers: Dry-chemical type.
- B. Fire-Protection Cabinets:
 - 1. Construction: Fire rated.
 - 2. Cabinet material: Enameled steel.
 - 3. Mounting: Semi-recessed.
 - 4. Door Material: Stainless steel.
 - 5. Door Glazing: Tempered break glass.
 - 6. Door Style: Fully glazed with frame.
- C. Accessories: Mounting brackets Break glass strike, lettered door handle, door locks, identification lettering.
- D. Finishes:
 - 1. Steel: Baked enamel.

END OF SECTION

SECTION 10675 - METAL STORAGE SHELVING

PART 1 - GENERAL

1.01 SUMMARY

- A. Metal storage shelving: 20" deep x 72" high open shelving system, self-supporting, with seismic anchorage to floor and walls.

END OF SECTION

SECTION 10800 - TOILET AND BATH ACCESSORIES

PART 1 - GENERAL

1.01 SUMMARY

A. Toilet and Bath Accessories:

1. Recessed with projecting receptacle combination towel dispenser/waste receptacles.
2. Liquid, surface mounted soap dispensers.
3. Concealed mounting stainless-steel grab bars.
4. Surface-mounted sanitary napkin vendors.
5. Combination surface-mounted toilet paper dispenser and seat-cover unit.
6. Combination surface-mounted toilet paper dispenser, seat-cover dispenser and sanitary napkin disposal unit.
7. Fixed utility shelf, one per toilet.
8. Heavy-duty shower rods, one per shower.
9. Vinyl antibacterial shower curtains and wire hooks, one set per shower.
10. Phenolic or polymeric composite folding shower seats, one per shower.
11. Recessed soap dish.
12. Single-prong robe hooks, three per shower.
13. Surface-mounted retractable clothes lines, one per shower.
14. Underlavatory piping insulation.

B. Mirrors:

1. Stainless-Steel Framed: Angle framed.

1.02 WARRANTY

- A. Mirrors: 15 years.

END OF SECTION

SECTION 11410 – LAUNDRY EQUIPMENT

PART 1 - GENERAL

1.01 SUMMARY

- A. Provide residential grade washer and dryer in living quarters.
- B. Coordinate work with Utilities required at equipment locations, as shown on plans.

1.01 SUMMARY

- A. Provide all materials, labor and equipment necessary to install Laundry equipment specified herein. Equipment shall be provided with seismic anchors upon installation.

PART 2 - PRODUCT

- A. Residential washer and dryer
 - 1. Washer: GE Model WBVH64240F or equal
 - 2. Electric Dryer: GE Model DBVH512EF or equal

PART 3 – INSTALLATION

- A Laundry Equipment:
 - 1. Install all equipment per the manufacturer's requirements.
 - 2. Coordinate installation of all laundry systems with utility requirements including electrical, gas, water, steam, exhaust vents and sanitary sewer.
 - 3. Provide seismic anchor bolts or tip over anchors at each unit.

END OF SECTION

SECTION 11451 - RESIDENTIAL EQUIPMENT

PART 1 – GENERAL

1.01 SUMMARY

- A. All kitchen equipment shall be new, unless otherwise noted.
- B. Contractor provided, Contractor installed items:
 - 1. Dishwasher: GE Tall Tub Dishwasher Model GLDA690MWW or equal
 - 2. Range/Oven: GE Electric range Model JBS15HWW or equal
 - 3. Hood: Broan NuTone Series NTM Model NTM30WH under cabinet mounted or equal
 - 4. Refrigerator/Freezer: GE Top Freezer Refrigerator with ice maker model GTS18KCP

END OF SECTION

SECTION 12512 - HORIZONTAL BLINDS

PART 1 - GENERAL

1.01 SUMMARY

- A. Venetian blinds for wall, (window head), mounting.

1.02 SUBMITTALS

- A. Schedule of blinds using room designations on Drawings.

1.03 QUALITY ASSURANCE

- A. Mockups for each form of construction and finish.

1.04 MATERIALS

- A. Louvers:
 - 1. Material: Aluminum.
 - 2. Width: 1 inch.
 - 3. Tilt Operation: Manual with wand.
 - 4. Lift Operation: Manual with chords.

1.05 INSTALLATION

- A. Install blinds between jambs.

END OF SECTION

SECTION 15050 - BASIC METHODS AND REQUIREMENTS

PART 1-GENERAL

1.01 GENERAL CONDITIONS

A. Section 15010, General Mechanical Requirements applies to this section.

1.02 SUMMARY

A. This section includes all plumbing (pipe and fittings, specialties) outside the portable buildings including connection to site plumbing systems and connections to stubs at the portable buildings.

1.03 RELATED SECTIONS

A. Section 15010 - General Mechanical Requirements

1.04 REFERENCES

A. PIPES AND TUBES

B. FITTINGS

B. JOINING MATERIALS

1.05 SUBMITTALS

PART 2 - PRODUCTS

2.01 GENERAL

2.02 PIPE, FITTING, AND JOINING MATERIALS

2.03 PIPE AND FITTING APPLICATIONS

A. Outside Building (from 5'-0" outside building line).

B. Connection to Building (within 5'-0" of building line).

2.04 VALVES

2.05 PIPING ACCESSORIES

PART 3 - EXECUTION

3.01 PIPING

3.02 VALVES, UNIONS AND FLANGES

3.03 INSTALLATION OF PIPING SYSTEMS

A. Thrust Blocks.

B. Sleeves.

C. Cathodic Protection.

D. Expansion.

3.04 INSTALLATION OF UNDERGROUND PIPE PROTECTION

3.05 EXCAVATING AND TRENCHING

3.06 BACKFILLING

- 3.07 CROSSING EXISTING UTILITIES
- 3.08 PROTECTION FROM DAMAGE
- 3.09 FINAL CONNECTIONS
- 3.10 STUBS
- 3.11 Piping Testing
 - A. Testing Criteria

END OF SECTION

SECTION 15250 - INSULATION

PART 1 - GENERAL

1.01 RELATED DOCUMENTS

- A. The requirements of the GENERAL CONDITIONS, SUPPLEMENTARY CONDITIONS, SPECIAL CONDITIONS and DIVISION 1 GENERAL REQUIREMENTS, apply to the work of this section.
- B. Section 15010, General Mechanical Requirements applies to this section.

1.02 SUMMARY

- A. This Section includes duct, pipe, and equipment insulation.
- B. Related Sections:
 - 1. Section 15050 – Basic Methods and Requirements
 - 2. Section 15400 - Plumbing
 - 3. Section 15510 - HVAC Piping and Valves
 - 4. Section 15800 - Heating, Ventilating, & Air Conditioning

1.03 QUALITY ASSURANCE

1.04 SUBMITTALS

PART 2-PRODUCTS

2.01 GENERAL

2.02 DUCT INSULATION MATERIALS

2.03 PIPE INSULATION MATERIALS

PART 3 - EXECUTION

3.01 GENERAL

3.02 DUCT INSULATION

3.03 PIPE INSULATION

3.04 FINISHING

END OF SECTION

SECTION 15400 - PLUMBING PIPING SYSTEMS

PART 1 - GENERAL

1.01 SUMMARY

- A. Cast Iron Soil Pipe and Fittings: Used for pipe buried in or in contact with earth and for extension of pipe to a distance of approximately 1500 mm (5 feet) outside of building walls and interior waste and vent piping above grade.
- B. Steel Pipe and Fittings: May be used for vent piping and storm water piping above grade.
- C. Interior Domestic Water Pipe: Copper tube, ASTM B88, Type K or L, drawn.
- D. Trap Primer Pipe: Copper tube, ASTM B88, Type K, hard drawn.
- E. Cleanouts: Same size as the pipe. Cleanouts shall be easily accessible. Provide a minimum clearance of 24 inches for rod out. Provide cleanouts at or near the base of the vertical stacks.
- F. Provide on all sanitary branch waste connections from fixtures or equipment not provided with traps.
- G. Provide a backflow prevention device at any point in the plumbing system where the potable water supply comes in contact with a potential source of contamination.
- H. Water Hammer Arrester: Closed copper tube chamber with permanently sealed 410 kPa (60 psig) air charge.

END OF SECTION

SECTION 15424 - DOMESTIC WATER HEATERS

PART 1 - GENERAL

1.01 SUMMARY

- A. Household, gas water heaters.

1.02 QUALITY ASSURANCE

- A. Gas Water Heaters: AGA certification labeled.
- B. Quality Standard for Water heater, Hot-Water Storage Tanks: ASME Boiler and Pressure Vessel Code.
- C. Performance Efficiency Standards:
 - 1. Household Water Heaters: ASHRAE 90.2.

1.03 WARRANTY

- A. Materials and Workmanship for Storage Tanks: 6 years.
- B. Materials and Workmanship for Circulators: 6 years.
- C. Materials and Workmanship for Burner Assemblies: 6 years.

1.04 PRODUCTS

- A. Household, Storage, Gas Water Heaters: ANSI Z21.10.1.
 - 1. Burner: For use with direct-vent water heaters.
 - a. Temperature Control: Adjustable thermostat.
 - b. Automatic ignition.
 - c. Automatic damper.
 - 2. Draft Hood: Low-profile-type, draft diverter.
 - 3. Direct-Vent System: Through-wall, double-channel vent assembly with outside intake/exhaust screen.
 - 4. Powered-Vent System: Interlocked with burner.
- B. Accessories:
 - 1. Combination temperature and pressure relief valves.
 - 2. Pressure relief valves.
 - 3. Vacuum relief valves.
 - 4. Gas Shutoff Valves: Manually operated.
 - 5. Gas pressure regulators.
 - 6. Automatic valves.

7. Water heater stand and drain pan units.
8. Water heater stands.
9. Water heater mounting brackets.
10. Drain pans.
11. Piping manifold kits.

END OF SECTION

SECTION 15450 - PLUMBING FIXTURES AND TRIM

PART 1 - GENERAL

1.01 SUMMARY

- A. Plumbing fixtures and related components.

1.02 QUALITY ASSURANCE

- A. Quality Standard: NSF 61 for fixture materials in contact with potable water.

1.03 MISCELLANEOUS FITTINGS AND ACCESSORIES

1.04 WATER CLOSETS

- A. Water Closets:
 - 1. Style.
 - 2. Bowl Type.
 - 3. Height.
 - 4. Design Consumption.
 - 5. Trip Mechanism.

1.06 LAVATORIES/SINKS

- A. Lavatories/Sinks.
 - 1. Type.
 - 2. Size.
 - 4. Hair interceptor.
 - 5. Protective shielding guards.

1.07 INDIVIDUAL SHOWERS

- A. Individual Showers: Accessible shower.
 - 1. Shower Faucet.

1.08 SERVICE SINKS

- A. Service Sinks.
 - 1. Size.
 - 2. Sink Faucet.

END OF SECTION

SECTION 15500 - FIRE PROTECTION

PART 1 - GENERAL

1.02 RELATED DOCUMENTS

- A. The requirements of the GENERAL CONDITIONS, SUPPLEMENTARY CONDITIONS, SPECIAL CONDITIONS and DIVISION 1 GENERAL REQUIREMENTS, apply to the work of this section.
- B. Section 15050, Basic Methods and Requirements applies to this section.

1.02 SUMMARY

- A. General: Furnish and install all materials and perform all labor necessary for the complete installation of a fire sprinkler system and related items to provide complete functional systems in accordance with the requirements of NFPA 13 and the 2001 CBC, in all areas of the building.
- B. General: Furnish and install all materials and perform all labor necessary to provide complete functional systems in accordance with the requirements of NFPA 13 and the local fire department.
 - 1. All pipe, fittings, sprinklers, hangers, valves, braces and all other accessories as necessary or required for a complete and operational system complying with all applicable codes.
 - 2. Diesel Fire Pump: Complete with controller, accessories, specialties, alarm panels and flowmeters, minimum .175 psig working pressure. Meet NFPA 20; UL 448.
- C. The contractor is responsible for securing approval from all agencies before submitting to the architect's office.

1.03 QUALITY ASSURANCE

1.04 RELATED SECTIONS

- A. Section 15400 - Plumbing
- B. Division 16 - Electrical Work.

1.05 SUBMITTALS

- A. Requirements
- B. Shop Drawings

PART 2 - PRODUCTS

2.01 GENERAL

- A. All materials and equipment shall be new and of latest design of the manufacturer and shall be tested and approved by the Underwriters Laboratories, Inc. and Factory Mutual.
- B. Sprinkler heads.
- C. Spare Sprinkler Heads.
- D. Freeze Protection.

E. Diesel Fire Pump.

2.02 PIPE AND FITTINGS

2.03 FIRE ALARM

A. Alarm Bell: Furnish and install UL listed, exterior and interior Fire Alarm Bells in a location approved by the architect.

2.04 SYSTEM TYPE

PART 3 - EXECUTION

3.01 INSTALLATION

A. Piping

3.02 SPRINKLER HEAD LOCATIONS

3.03 COORDINATION

3.04 REPORTS

3.05 DETECTION, ALARM, AND ELECTRICAL WIRING

END OF SECTION

SECTION 15562 - MAKEUP AIR UNITS

PART 1 - GENERAL

1.01 SUMMARY

- A. Unit Enclosure: Completely weatherized galvanized steel enclosure with removable access panels for outdoors installation and properly reinforced and braced. provide panels and access doors for inspection and access to all internal parts. Surface of steel parts shall be factory corrosion protected by a painting or coating system.
- B. Indirect-fired, modulating propane burner, 80% efficiency. Stainless steel heat exchanger.
- C. Supply Air/Fans: Forward curved or backward inclined centrifugal.
- D. Provide filter boxes with either hinged access doors or removable panels.

END OF SECTION

SECTION 15735 - PACKAGED AIR CONDITIONING EQUIPMENT

PART 1 - GENERAL

1.01 SUMMARY

- A. Packaged, through-the-wall terminal air conditioners as heat-pump unit with electric-resistance heating.

1.02 QUALITY ASSURANCE

- A. Energy-Efficiency Ratio: ASHRAE/IESNA 90.1.
- B. Coefficient of Performance: ASHRAE/IESNA 90.1.

1.03 WARRANTY

- A. Materials and Workmanship for Sealed Refrigeration System: Five years.
- B. Materials and Workmanship for Heat Exchanger: Five years.

1.04 MANUFACTURED UNITS

- A. General: Factory-assembled and tested, self-contained, packaged terminal air conditioner with room cabinet, electric refrigeration system, heating and temperature controls.
 - 1. Power Supply: Cord-connected chassis, 230/208 V.
- B. Cabinet: Galvanized steel with removable front panel.
 - 1. Mounting: Wall with wall sleeve.
 - 2. Finish: Baked enamel.
 - 3. Discharge Grille and Access Door: Punched louver, allowing four-way discharge.
 - 4. Cabinet extensions matching cabinet construction.
 - 5. Subbase: Enameled steel with factory-installed and wired, fused disconnect switch and receptacle.
 - 6. Wall Sleeves: Molded polymer.
 - 7. Louvers: Stamped aluminum with clear-anodized finish.
- C. Refrigeration System: Direct-expansion indoor coil with capillary restrictor, hermetically sealed scroll compressor and outdoor coil and fan.
 - 1. Accumulator, constant-pressure expansion valve, and reversing valve for heat-pump units.
- D. Indoor Fan: Forward curved, centrifugal, with motor and positive-pressure ventilation damper with concealed manual operator.

- E. Filters in molded plastic frame.
- F. Supplemental Heating: Electric-resistance heating coil.
- G. Condensate Drain: Direct condensate to outdoor coil.
- H. Outdoor Fan: Propeller type with driven by indoor fan motor.
- I. Controls: Unit-mounted, adjustable-thermostat control-module; low ambient lockout control; and heat-pump ambient control.
 - 1. Fan-cycle switch.
 - 2. Temperature-limit control.
 - 3. Compressor override.
 - 4. Programmable thermostat.
 - 5. Reverse-cycle defrost.

1.05 SOURCE QUALITY CONTROL

- A. Unit Performance Ratings: Factory tested to comply with ARI 310/380.

END OF SECTION

SECTION 15772 - RADIANT TUBE HEATERS

PART 1 - GENERAL

1.01 SUMMARY

- A. Propane fired, single stage, infra-red radiant tube heater.
- B. Coated titanium or aluminized combustion chamber.
- C. Stainless steel burner, polished aluminum reflectors.
- D. Hot surface ignition with flame rod sensing.
- E. CSA certified, 10 year burner warranty.

END OF SECTION

SECTION 15840 - DUCTWORK AND ACCESSORIES

PART 1 - GENERAL

1.01 SUMMARY

- A. Dampers, silencers, turning vanes, duct-mounted access doors and flexible ducts and connectors.

1.02 QUALITY ASSURANCE

- A. Installation Standards: NFPA 90A and NFPA 90B.

1.03 PRODUCTS

- A. Backdraft Dampers: Multiple blade, parallel action, gravity balanced.
 - 1. Frames: Extruded aluminum.
 - 2. Blades: Roll-formed aluminum.
 - 3. Blade Seals: Neoprene.
 - 4. Blade Axles: Galvanized steel.
 - 5. Tie Bars and Brackets: Aluminum.
 - 6. Return spring.
- B. Standard Volume Dampers: Multiple or single-blade, parallel or opposed-blade design, with linkage outside airstream.
 - 1. Frames: Aluminum.
 - 2. Blades: Aluminum sheet.
 - 3. Blade Axles: Galvanized steel.
 - 4. Tie Bars and Brackets: Aluminum.
- C. Combination Fire and Smoke Dampers: UL labeled.
 - 1. Fusible Links: Replaceable, 165 deg F rated.
 - 2. Frame and Blades: Galvanized steel.
 - 3. Damper Motors: Spring return.
- D. Manufactured Turning Vanes: Single-blade, galvanized sheet steel.
- E. Pressure Relief Access Doors: Single wall, and duct mounting.

END OF SECTION

SECTION 15885 - AIR FILTERS

PART 1 - GENERAL

1.01 SUMMARY

- A. Air filters for heating, ventilating and air conditioning.
- B. Use factory assembled air filters of the extended surface type with supported or non-supported cartridges for removal of particulate matter in air conditioning, heating and ventilating systems. Filter units shall be of the extended surface type fabricated for disposal when the dust-load limit is reached as indicated by maximum (final) pressure drop.
- C. Pre-filter: Grade D: 25-30 prefilter, when handling 3.0 to 10.0 micron particles.

END OF SECTION

SECTION 15902 - CONTROLS AND INSTRUMENTATION (DDC)

PART 1 - GENERAL

1.01 RELATED DOCUMENTS

- A. The requirements of the GENERAL CONDITIONS, SUPPLEMENTARY CONDITIONS, SPECIAL CONDITIONS and DIVISION 1 GENERAL REQUIREMENTS, apply to the work of this section.

1.02 SUMMARY

- A. General
 - 1. Furnish all labor, materials, equipment, and service necessary for a complete and operating temperature control system utilizing Controls as shown on the drawings and as specified herein to provide a complete and operational system.
 - 2. All labor, material, equipment and software necessary to meet the functional intent of the Temperature Control systems as specified herein and as shown on the drawings shall be included.

1.03 REFERENCES

- A. NEMA - National Electrical Manufacturer's Association.
- B. UL - Underwriter's Laboratories , Inc.
- C. NFPA - 70 National Electric Code (NEC).
- D. Title 24 California Code of Regulation (CCR) Title 24, Part 3, Basic Electrical Requirements, State Building Standards Electric Code.

1.04 SUBMITTALS

1.05 QUALITY ASSURANCE

1.06 SUBMITTALS

PART 2 - PRODUCTS

2.01 GENERAL

2.02 WIRES, CABLES AND TERMINATIONS

2.03 THERMOSTATS AND INSTRUMENTATION

2.04 OPERATOR INTERFACE – PLATFORM

2.05 INPUT DEVICES

2.06 OUTPUT DEVICES

PART 3 - EXECUTION

3.01 GENERAL

3.02 INSTALLATION

- A. Electrical Work
- B. Conduits

C. Thermostats

3.03 RECORD DRAWINGS

3.04 WARRANTY AND SERVICE

END OF SECTION

SECTION 15980 - TESTING, ADJUSTING AND BALANCING

PART 1 - GENERAL

1.01 SUMMARY

- A. Testing, adjusting and balancing for the following:
 - 1. Air Systems: Constant-volume.
 - 2. Motors.
 - 3. Heat-transfer coils.
 - 4. Temperature measurements.
 - 5. Space pressurization measurements and adjustments.
 - 6. Temperature-control verification.

1.02 QUALITY ASSURANCE

- A. Testing, Adjusting and Balancing Agent Qualifications: AABC certified.

1.03 WARRANTY

- A. Guarantee: AABC national project performance guarantee that a certified agent has performed TAB and optimum performance capabilities have been achieved.

1.04 EXECUTION

- A. Testing, adjusting and balancing plan.
- B. Systems readiness checks.
- C. Testing, Adjusting and Balancing Procedures: AABC's "National Standards for Testing and Balancing Heating, Ventilating and Air Conditioning Systems">
- D. Equipment settings marked to show final settings.
- E. HVAC Systems Airflow and Water Flow Rate Tolerances:
- F. Reporting:

END OF SECTION

SECTION 16010 - BASIC ELECTRICAL REQUIREMENTS

PART 1 - GENERAL

1.01 SUMMARY

- A. Applicable codes and standards: All systems shall be designed in accordance with the National Electrical Code, latest edition (NEC), Uniform Building Code, latest edition (UBC), California Energy Conservation Code (Title 24), and local codes and standards.
- B. Work included in this Section: All materials, labor, equipment, services, and incidentals necessary to install the Electrical Work as specified hereinafter, including, but not limited to the following:
 - 1. Electrical and telephone services provisions as outlined, including temporary power for construction.
 - 2. Main switchboard, branch panels, transformers and all feeders.
 - 3. Branch circuit wiring, wiring devices and connections to all equipment requiring electrical service.
 - 4. Lighting fixtures (interior and exterior) completely lamped.
 - 5. Emergency egress/exit illumination system.
 - 6. Telephone/Data outlet boxes, conduit and wiring.
 - 7. Fire Alarm System.
- C. Fire Stopping and Fire Rated Penetrations:
 - 1. All electrical equipment mounted in, on or through fire rated construction shall be installed to maintain the fire rating of the construction.
 - 2. Provide fire rated pads (or other suitable assembly) around all electrical junction boxes in fire rated walls/ceilings/floors to maintain the fire rating.
 - 3. Provide fire rated construction around all recessed light fixtures and/or panel board/cabinets mounted flush in fire rated walls to maintain the fire rating. Coordinate depth of construction with other trades to avoid conflicts.

END OF SECTION

SECTION 16050 - BASIC ELECTRICAL MATERIALS AND METHODS

PART 1 - GENERAL

1.01 SUMMARY

- A. Raceways: Building wire and connectors: supporting devices for electrical components; electrical identification; concrete equipment bases; electrical demolition; and cutting and patching for electrical construction.

1.02 MATERIALS

- A. Raceways: EMT, FMC, IMC, LFMC.
- B. Conductors: Copper.
- C. Supporting Devices: Slotted-steel channels, galvanized for outdoors and damp locations.
- D. Electrical Identification:
 - 1. Raceway and Cable labels: Wraparound plastic sleeves, Self-adhesive vinyl, Colored adhesive marking tape.
 - 2. Underground Line Warning Tape: Colored vinyl.
 - 3. Tape markers for wire.
 - 4. Signs and Instruction Plates: Engraved plastic.

1.03 INSTALLATION

- A. Wiring Methods:
 - 1. Feeders: Type THHN/THWN insulated conductors in raceway.
 - 2. Underground Feeders and Branch Circuits; Type THWN or single-wire, Type UF insulated conductors in raceway.
 - 3. Branch Circuits: Type THHN/THWN insulated conductors in raceway THW or THHN/THWN insulated conductors in raceway where exposed.
 - 4. Remote-Control Signaling and Power-Limited Circuits: Type THHN/THWN insulated conductors in raceway.

END OF SECTION

SECTION 16400 - SERVICE & DISTRIBUTION

PART 1 - GENERAL

1.01 GENERAL

- A. Applicable portions of other Sections within Division 16 are a part of this Section except as supplemented or modified by this Section.
- B. Install electrical service and distribution system as shown and specified.

1.02 WORK NOT INCLUDED IN THIS SECTION

- A. Utility company service transformers.
- B. That conduit or conductors furnished by the Utility company.

1.03 SUBMITTALS

- A. Submit drawings of switchboard showing metering facilities to utility power company and obtain their approval before submitting to the Engineer.

1.04 SERVICE AND DISTRIBUTION SYSTEM

- A. Power service shall be taken from the existing 3-phase overhead lines located at the east side of the site. Service shall be at 277/480V 3PH 4W from a new utility company pad-mounted transformer. The pad-mounted transformer and primary and secondary service conductors are to be provided by the Utility Company. The concrete transformer pad, grounding, underground primary service conduits, underground secondary service conduits and main switchboard are to be provided under this contract. Contractor shall pay all Utility Company service charges and comply with all Utility Company requirements.
- B. The Main Switchboard shall be a 2000 Amp 277/480V 3-Phase Switchboard with metering Equipment. The single above grade, free-standing switchboard will be sized to accommodate the entire facility load (current and future). The switchboard shall contain an incoming utility section, a meter/main section, and a distribution section for outgoing feeders.
- C. The project shall include (2) paralleled 150 KW propane emergency power generators (277/480V, 3-Phase) set up as a 300KW emergency back-up source. System shall be as manufactured by Generac Power Systems, MPS series, or equal, with all paralleling electronics on-board generator units (no additional switchgear or controls required). System to include a 2000A automatic transfer switch.

HAMMIL VALLEY ES STATION
MONO COUNTY, CALIFORNIA
DEPT. OF PUBLIC WORKS

BUDGET PACKAGE PHASE
OUTLINE SPECIFICATIONS

PART 2 - PRODUCTS

2.01 TRANSFORMERS

PART 3 - EXECUTION

3.01 TRANSFORMER INSTALLATION

END OF SECTION

SECTION 16500 - LIGHTING

PART 1 - GENERAL

1.01 CONTRACT PROVISIONS

The requirements of this section are in addition to the requirements of Division 1, General Conditions, Supplementary Conditions, and Section 16050 - Basic Materials and Methods bound herewith.

1.02 REQUIREMENTS

- A. Lighting fixtures shall metal halide, compact fluorescent, and T8 fluorescent lamp sources with electronic ballasts and high efficiency reflectors.
- B. The design shall follow the architectural design criteria and the recommendations of The Illuminating Engineering Society of North America.
- C. All ballasts shall be Class A sound rated for minimum sound output. All ballasts used at exterior locations shall be zero degree start rated.
- D. Emergency lighting shall be provided as required by code and shall consist of battery back-up ballasts in selected fluorescent fixtures. The emergency lighting system shall provide a minimum of 1 foot candle throughout the paths of egress, per the CBC.

PART 2 - PRODUCTS

2.01 LUMINAIRES

2.02 BALLASTS

2.03 LAMPS

PART 3 - EXECUTION

3.01 INSTALLATION

END OF SECTION

SECTION 16720 - FIRE ALARM SYSTEM

PART 1 - GENERAL

1.01 SUMMARY

- A. A Class B, supervised, intelligent/addressable Fire alarm system shall be provided for the facility. The system shall include a separate Central Control Panel and Annunciator at the Residence Building. Devices shall include pull stations at exits in each building, audio-visual alarm indicating devices throughout, connections to duct smoke detectors provided under Division 15, fire suppression system waterflow and valve supervisory switch connections, provisions for system monitoring by approved Central Monitoring Station, and all other system components including equipment, raceways, conductors and connections.
- B. All alarms shall automatically be annunciated via a recorded message.

1.02 SUBMITTALS

- A. Submittals to local Fire Marshal.
- B. Coordination Drawings for duct smoke detectors.

1.03 QUALITY ASSURANCE

- A. Standard: NFPA 72.

1.04 PRODUCTS

- A. System Function:
 - 1. Transmission to central fire alarm monitoring system.
 - 2. Alarm Capability during Circuit Fault Conditions.
 - 3. Loss of primary power trouble signal.
 - 4. Alarm Initiation.
 - 5. Alarm Silencing, System Reset and Indication.
- B. Manual Pull Stations: Double-action type with indoor protective shield.
- C. Smoke Detectors.
 - 1. Types.
- D. Other Detectors.
- E. Notification Appliances:
 - 1. Bells.
 - 2. Chimes.
 - 3. Visual alarm devices.

- F. Central Fire Alarm Control Panel:
- G. Remote Annunciator:
- H. Emergency Power Supply: Battery, charger and automatic transfer switch.

1.05 FIELD QUALITY CONTROL

- A. Factory-authorized service representative to pretest system.
- B. Test Procedure: NFPA 72.

END OF SECTION

SECTION 16950 - TESTING

PART 1 - GENERAL

1.01 SUMMARY

- A. The electrical installation shall be inspected and tested to ensure safety to the building occupants, operating personnel and conformity to code authorities.
- B. The Contractor shall engage the services of a recognized corporate and financially independent testing firm, ETI or equal, for the purpose of performing the following inspections and tests:
 - 1. System grounding.
 - 2. Main switchgear.
 - 3. Feeders.
 - 4. Lighting fixtures.

END OF SECTION



View of property facing southwest.



View of property facing west.



View of property facing northwest.



View of property across Highway 6 facing southeast.



View of property across Highway 6 facing east.



View of property across Highway 6 facing northeast.



Power pole on west side of Highway 6 located mid parcel.

REVISIONS

NO.	DESCRIPTION	DATE

DRAWN BY: MD CHK. BY: KD

HAMMIL VALLEY
EMERGENCY
SERVICES STATION
HIGHWAY 6
DRAFT

ALL DRAWINGS AND WRITTEN MATERIAL
APPEARING HEREIN CONSTITUTE ORIGINAL
AND UNPUBLISHED WORK OF HMR ARCHITECTS
AND MAY NOT BE DUPLICATED, USED OR
DISCLOSED WITHOUT WRITTEN CONSENT
OF HMR ARCHITECTS.

10049

JUNE 30, 2011

AS-1.0

1 OF 17

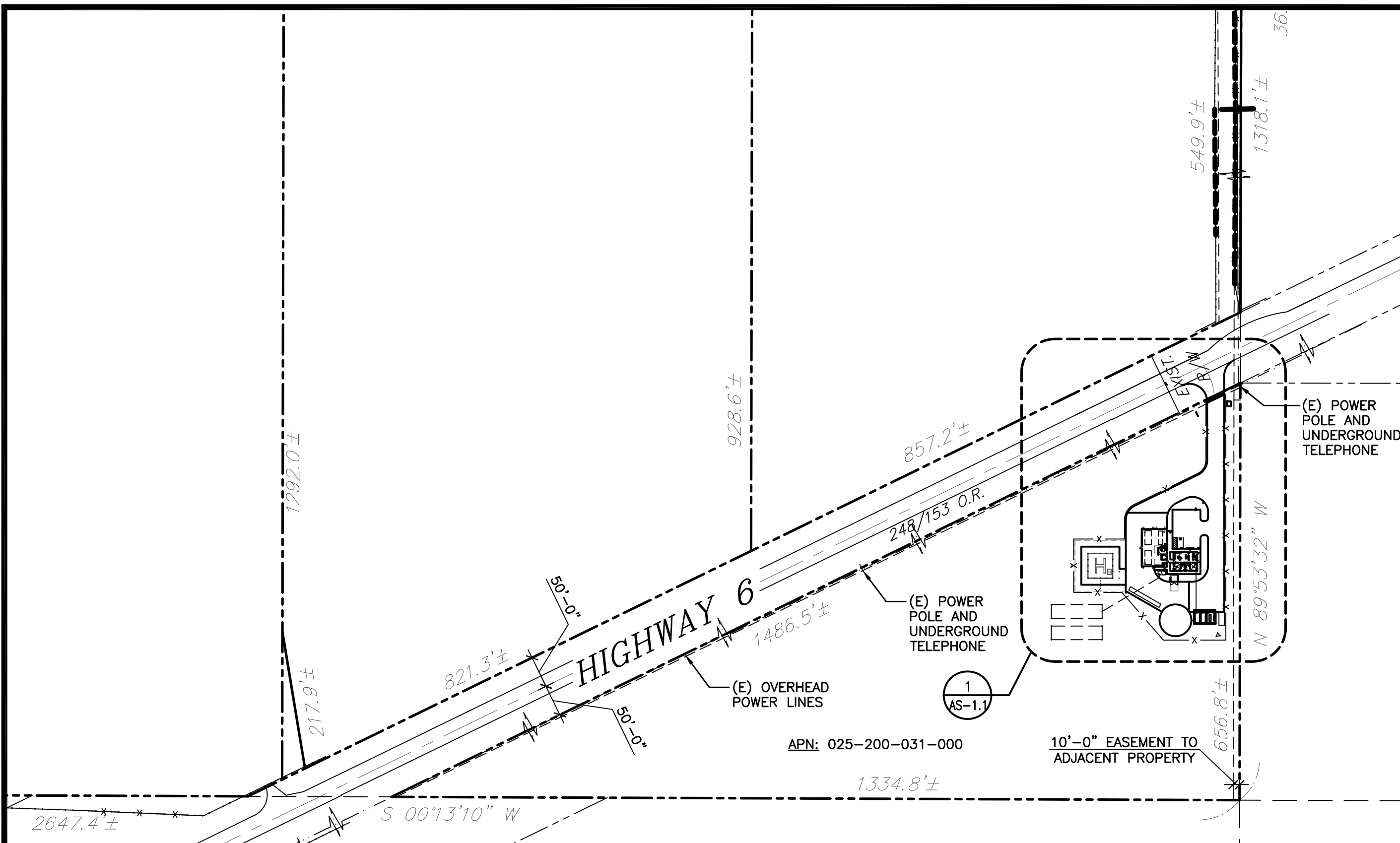

1 SITE PLAN
AS-1.0

FILE: HVESS_SITE_1_P





NORTH

SCALE: 1"=150'-0"

KEYNOTES

- (S1) HELIPAD WITH LANDING LIGHTS
- (S2) WIND SOCK
- (S3) APPARATUS BLDG.
- (S4) PUMP/WELL/GENERATOR BLDG.
- (S5) FOUR STRAND BARBED WIRE FENCE W/CATTLE GATE
- (S6) 1,500 GAL. PROPANE TANK FOR GENERATOR
- (S7) CELLULAR TOWER
- (S8) CONCRETE MONUMENT SIGN
- (S9) FLAG POLE
- (S10) RESIDENCE
- (S11) HOSE WASH RACK
- (S12) SEPTIC TANK
- (S13) LEACH FIELD
- (S14) TRASH ENCLOSURE
- (S15) OFFSITE STANDARD DRIVEWAY CUT PER CALTRANS
- (S16) TRANSFORMER
- (S17) LIGHT POLE
- (S18) 60,000 GALLON FIRE STORAGE TANK, 8'-0" HIGH
- (S19) FIRE HYDRANT
- (S20) POWER POLE WITH UNDERGROUND TELEPHONE

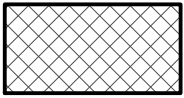
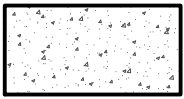
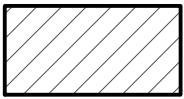
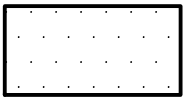
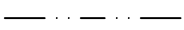
LEGEND

-  A/C PAVING
-  CONCRETE FLATWORK
-  LANDSCAPE AREA
-  COMPACTED AGGREGATE BASE
-  (E) OVERHEAD POWER LINES
-  PROPERTY LINE
- TLOF TOUCHDOWN AND LIFT OFF AREA
- FATO FINAL APPROACH AND TAKE OFF

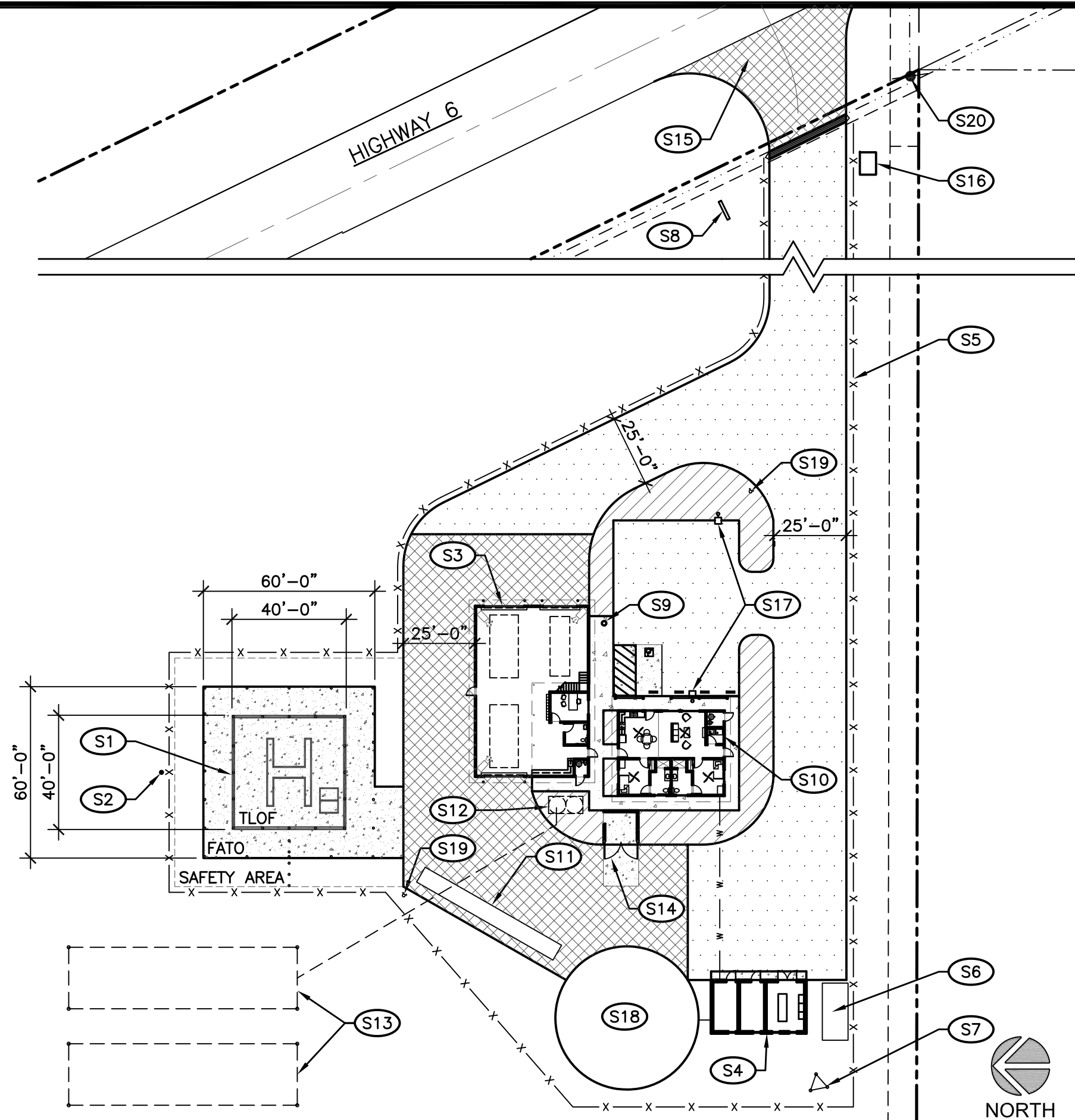

REVISIONS

NO.	DESCRIPTION	DATE

DRAWN BY: MD CHK. BY: KD

HAMMIL VALLEY
EMERGENCY
SERVICES STATION
HIGHWAY 6
DRAFT

ALL DRAWINGS AND WRITTEN MATERIAL APPEARING HEREIN CONSTITUTE ORIGINAL AND UNPUBLISHED WORK OF HMR ARCHITECTS AND MAY NOT BE DUPLICATED, USED OR DISCLOSED WITHOUT WRITTEN CONSENT OF HMR ARCHITECTS.

10049

JUNE 30, 2011

AS-1.1

2 OF 17

1 ENLARGED SITE PLAN

AS-1.1 FILE: HVESS_SITE_ENL_1_P

SCALE: 1"=40'-0"

REVISIONS

NO.	DESCRIPTION	DATE

NOTE:
VCT IN OFFICE.
REMAINDER SHALL BE
SEALED CONCRETE.

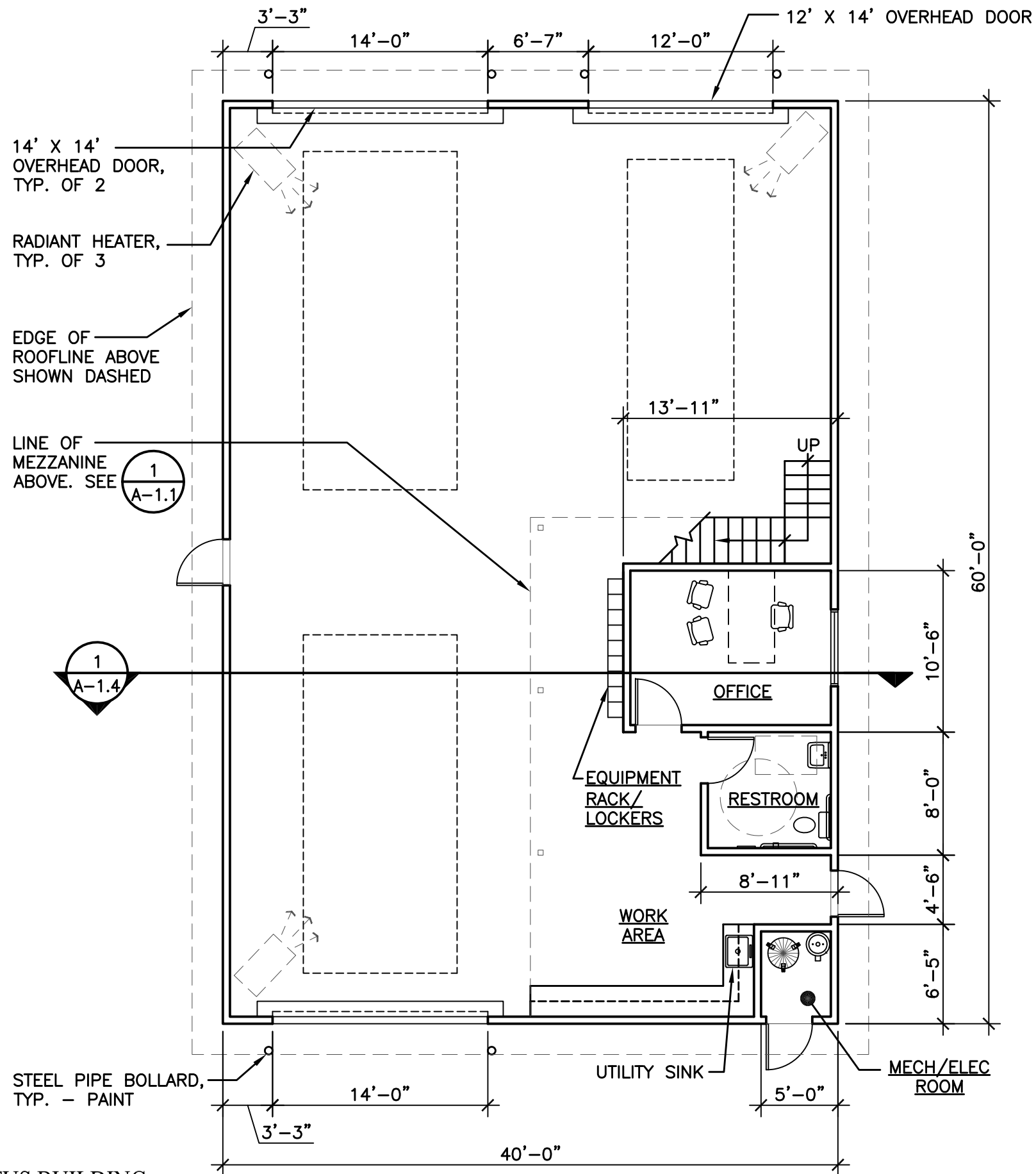

14' X 14'
OVERHEAD DOOR,
TYP. OF 2

RADIANT HEATER,
TYP. OF 3

EDGE OF
ROOFLINE ABOVE
SHOWN DASHED

LINE OF
MEZZANINE
ABOVE. SEE
1
A-1.1

1
A-1.4

STEEL PIPE BOLLARD,
TYP. - PAINT

1 FLOOR PLAN - APPARATUS BUILDING

A-1.0 FILE: HVESS_FLR_APP_1_P



SCALE: 1/8"=1'-0"

DRAWN BY: MD CHK. BY: KD

HAMMIL VALLEY
EMERGENCY
SERVICES STATION
HIGHWAY 6
DRAFT

ALL DRAWINGS AND WRITTEN MATERIAL
APPEARING HEREIN CONSTITUTE ORIGINAL
AND UNPUBLISHED WORK OF HMR ARCHITECTS
AND MAY NOT BE DUPLICATED, USED OR
DISCLOSED WITHOUT WRITTEN CONSENT
OF HMR ARCHITECTS.

10049

JUNE 30, 2011

A-1.0

3 OF 17

REVISIONS

NO.	DESCRIPTION	DATE

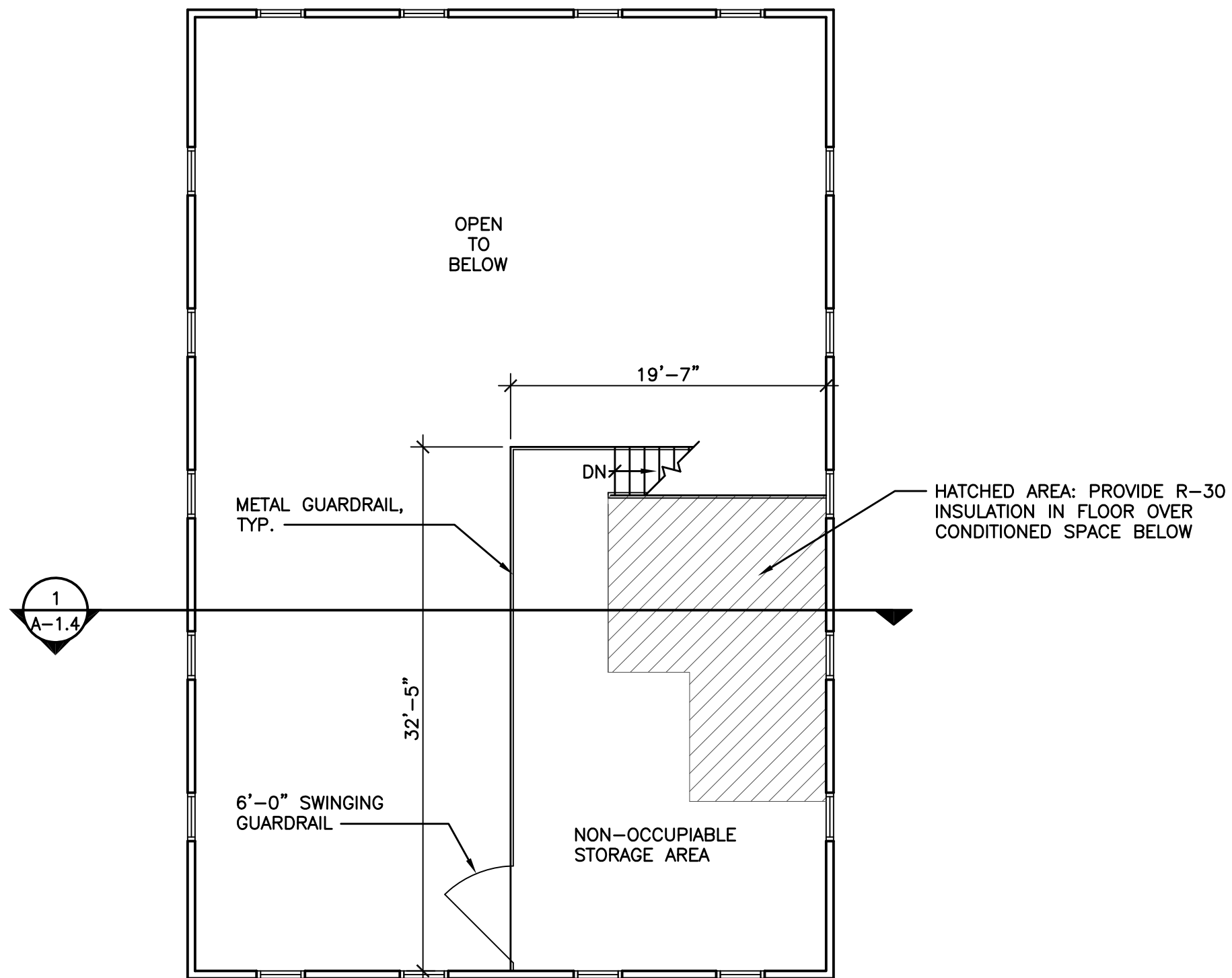

DRAWN BY: MD CHK. BY: KD

HAMMIL VALLEY
EMERGENCY
SERVICES STATION
HIGHWAY 6
DRAFT

ALL DRAWINGS AND WRITTEN MATERIAL
APPEARING HEREIN CONSTITUTE ORIGINAL
AND UNPUBLISHED WORK OF HMR ARCHITECTS
AND MAY NOT BE DUPLICATED, USED OR
DISCLOSED WITHOUT WRITTEN CONSENT
OF HMR ARCHITECTS.



NORTH

10049

JUNE 30, 2011

A-1.1

4 OF 17

1 MEZZANINE FLOOR PLAN - APPARATUS BUILDING

A-1.1 FILE: HVESS_FLR_APP_MEZZ_P

SCALE: 1/8"=1'-0"

REVISIONS

NO.	DESCRIPTION	DATE

DRAWN BY: MD CHK. BY: KD

HAMMIL VALLEY
EMERGENCY
SERVICES STATION
HIGHWAY 6

DRAFT

ALL DRAWINGS AND WRITTEN MATERIAL
APPEARING HEREIN CONSTITUTE ORIGINAL
AND UNPUBLISHED WORK OF HMR ARCHITECTS
AND MAY NOT BE DUPLICATED, USED OR
DISCLOSED WITHOUT WRITTEN CONSENT
OF HMR ARCHITECTS.

10049

JUNE 30, 2011

A-1.2

5 OF 17

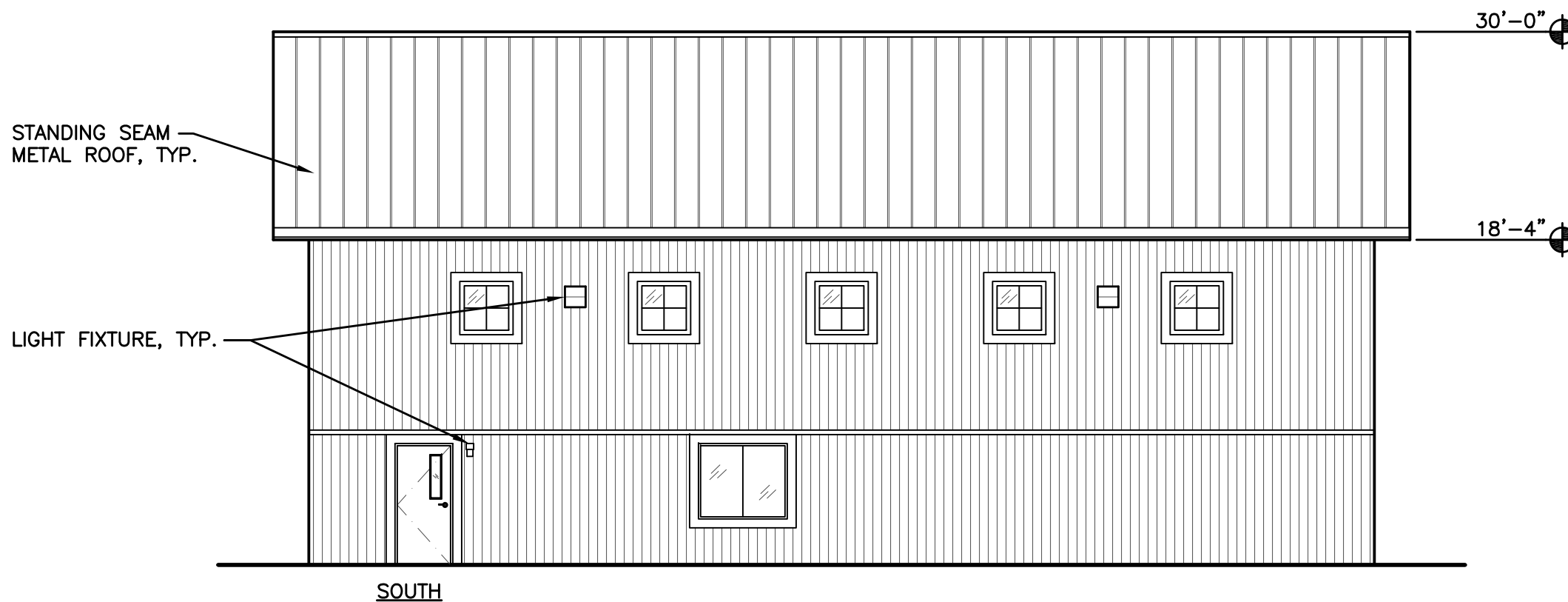
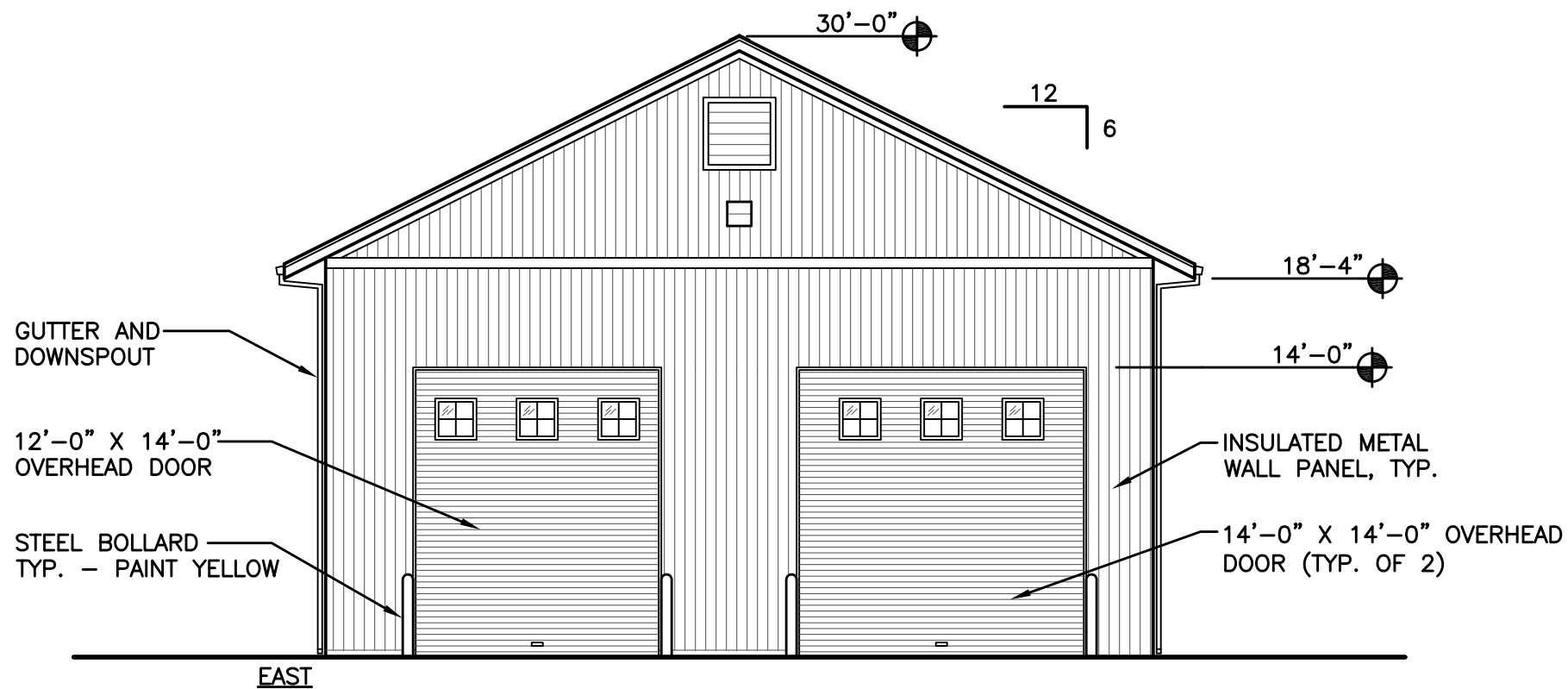

1 EXTERIOR ELEVATION - APPARATUS BUILDING

A-1.2 FILE: HVESS_XEL_APP

SCALE: 1/8"=1'-0"

FOR ADDITIONAL NOTES,
SEE A-1.2

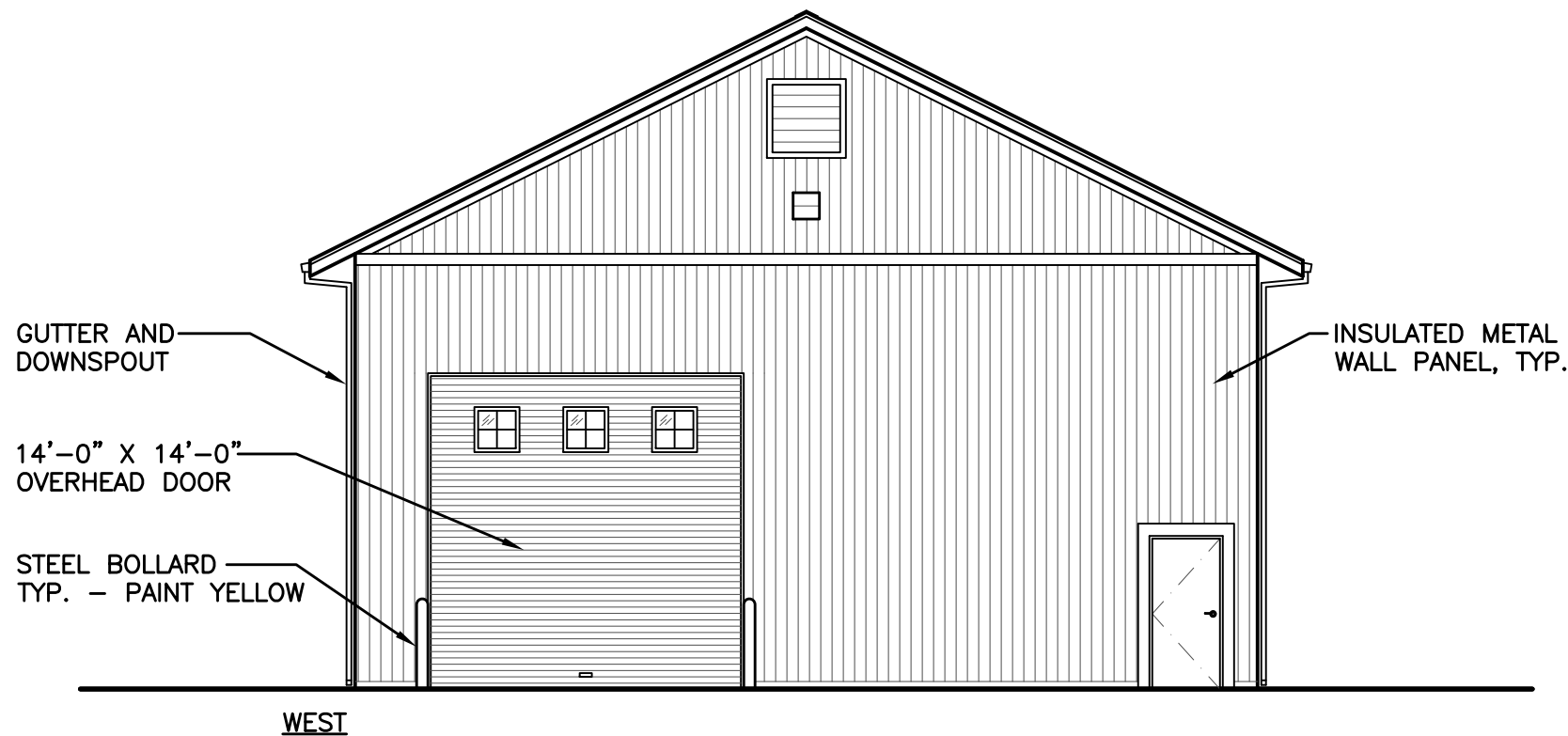

REVISIONS		
NO.	DESCRIPTION	DATE

DRAWN BY: MO CHK. BY: KD

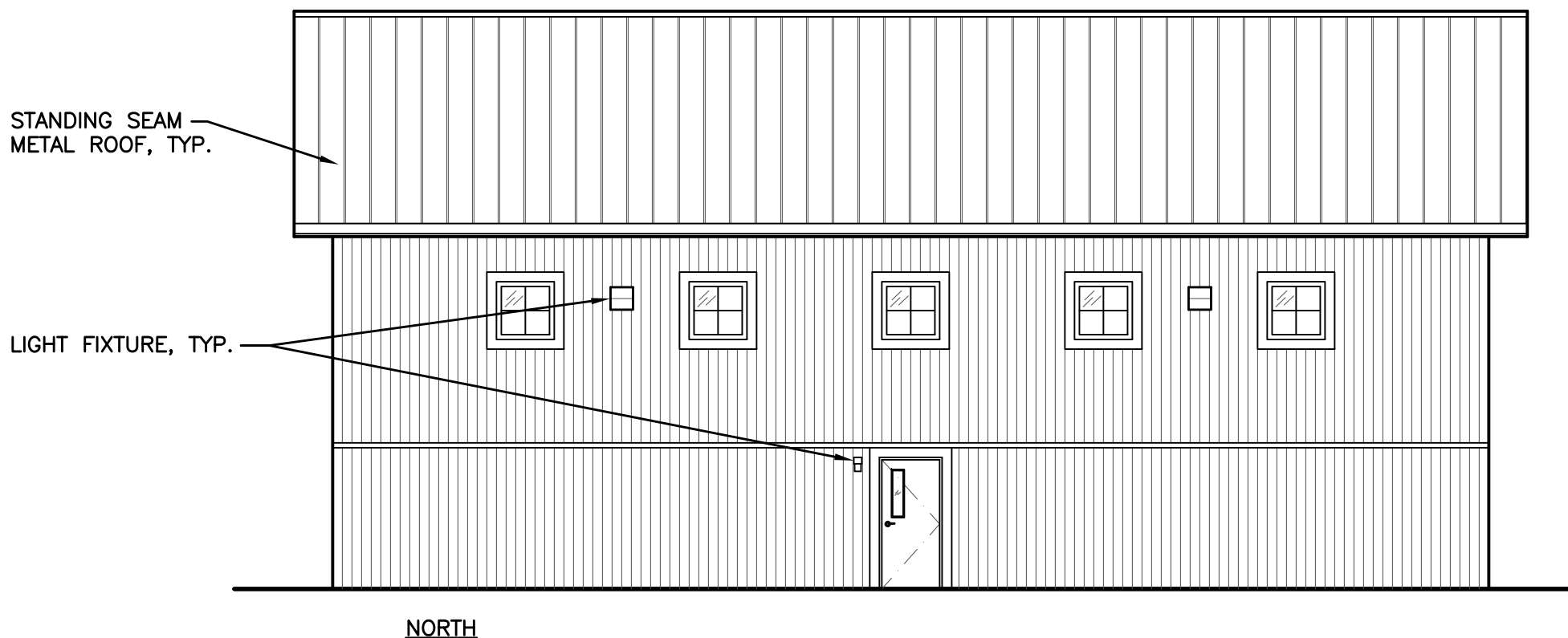

HAMMIL VALLEY
EMERGENCY
SERVICES STATION
HIGHWAY 6
DRAFT

ALL DRAWINGS AND WRITTEN MATERIAL
APPEARING HEREIN CONSTITUTE ORIGINAL
AND UNPUBLISHED WORK OF HMR ARCHITECTS
AND MAY NOT BE DUPLICATED, USED OR
DISCLOSED WITHOUT WRITTEN CONSENT
OF HMR ARCHITECTS.

10049

JUNE 30, 2011

A-1.3

6 OF 17

1 EXTERIOR ELEVATION - APPARATUS BUILDING

A-1.3 FILE: HVESS_XEL_APP

SCALE: 1/8"=1'-0"

REVISIONS

NO.	DESCRIPTION	DATE

DRAWN BY: MD CHK. BY: KD

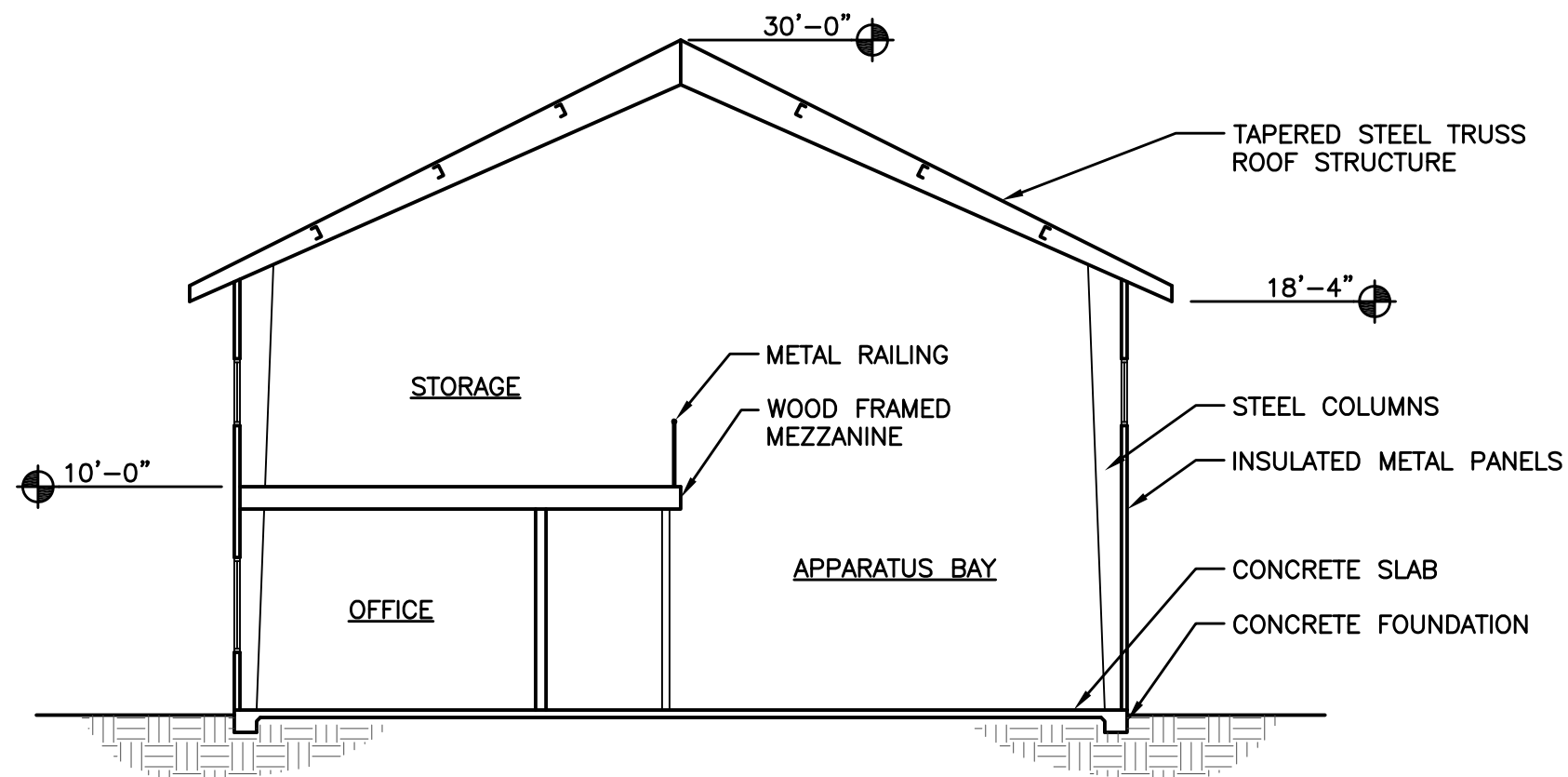

HAMMIL VALLEY
EMERGENCY
SERVICES STATION
HIGHWAY 6

DRAFT

ALL DRAWINGS AND WRITTEN MATERIAL
APPEARING HEREIN CONSTITUTE ORIGINAL
AND UNPUBLISHED WORK OF HMR ARCHITECTS
AND MAY NOT BE DUPLICATED, USED OR
DISCLOSED WITHOUT WRITTEN CONSENT
OF HMR ARCHITECTS.

10049

JUNE 30, 2011

A-1.4

7 OF 17

1
A-1.4

SECTION THRU APPARATUS BUILDING

FILE: HVESS_SEC

SCALE: 1/8"=1'-0"

REVISIONS

NO.	DESCRIPTION	DATE

DRAWN BY: MD CHK. BY: KD

HAMMIL VALLEY
EMERGENCY
SERVICES STATION
HIGHWAY 6

DRAFT

ALL DRAWINGS AND WRITTEN MATERIAL
APPEARING HEREIN CONSTITUTE ORIGINAL
AND UNPUBLISHED WORK OF HMR ARCHITECTS
AND MAY NOT BE DUPLICATED, USED OR
DISCLOSED WITHOUT WRITTEN CONSENT
OF HMR ARCHITECTS.



10049

JUNE 30, 2011

A-2.0

11 OF 17

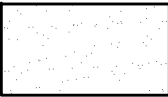
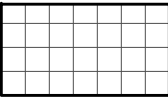
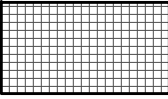
FLOORING LEGEND

-  CARPET
-  SHEET VINYL
-  CERAMIC TILE
-  SEALED CONCRETE

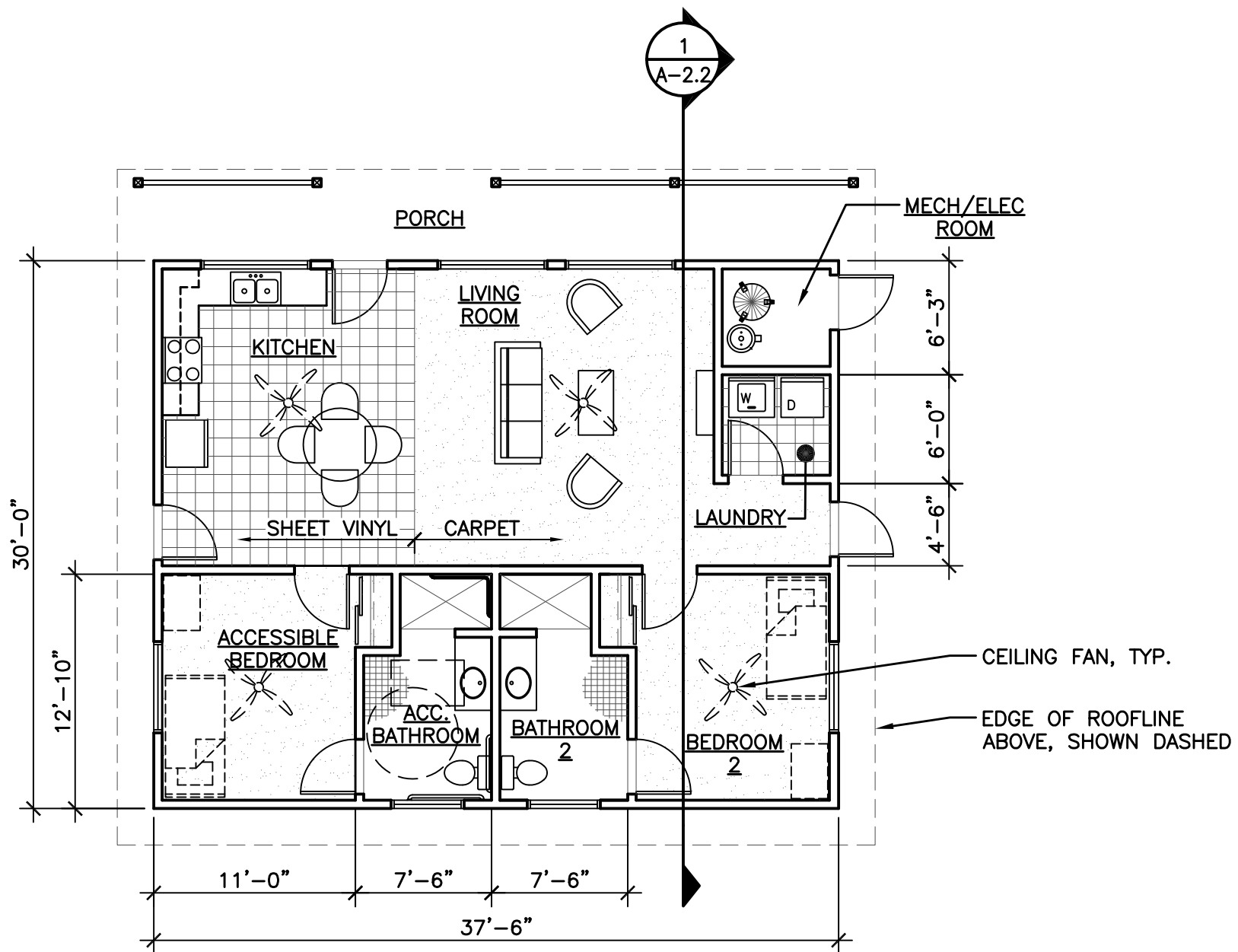

1 FLOOR PLAN
A-2.0

FILE: HVESS_FLR_HOUSE_1_P



SCALE: 1/8"=1'-0"

REVISIONS

NO.	DESCRIPTION	DATE

DRAWN BY: MD CHK. BY: KD

HAMMIL VALLEY
EMERGENCY
SERVICES STATION
HIGHWAY 6
DRAFT

ALL DRAWINGS AND WRITTEN MATERIAL
APPEARING HEREIN CONSTITUTE ORIGINAL
AND UNPUBLISHED WORK OF HMR ARCHITECTS
AND MAY NOT BE DUPLICATED, USED OR
DISCLOSED WITHOUT WRITTEN CONSENT
OF HMR ARCHITECTS.

10049

JUNE 30, 2011

A-2.1

12 OF 17

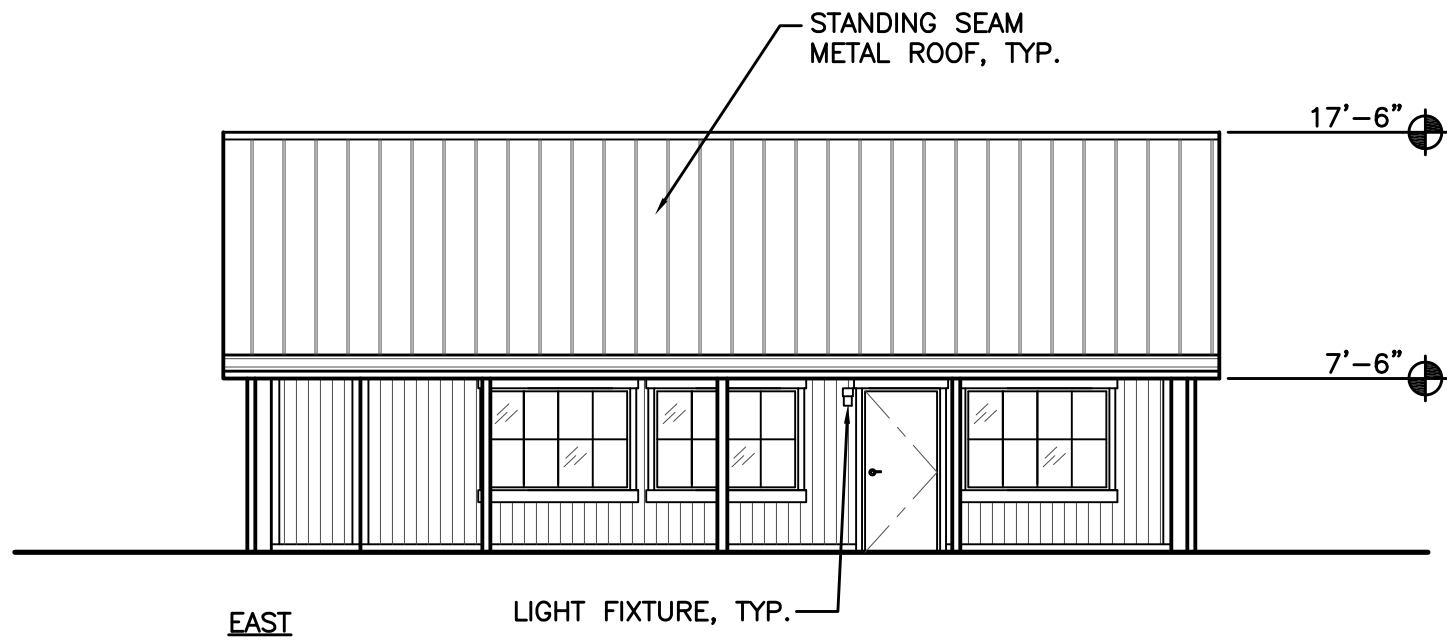

EAST

LIGHT FIXTURE, TYP.

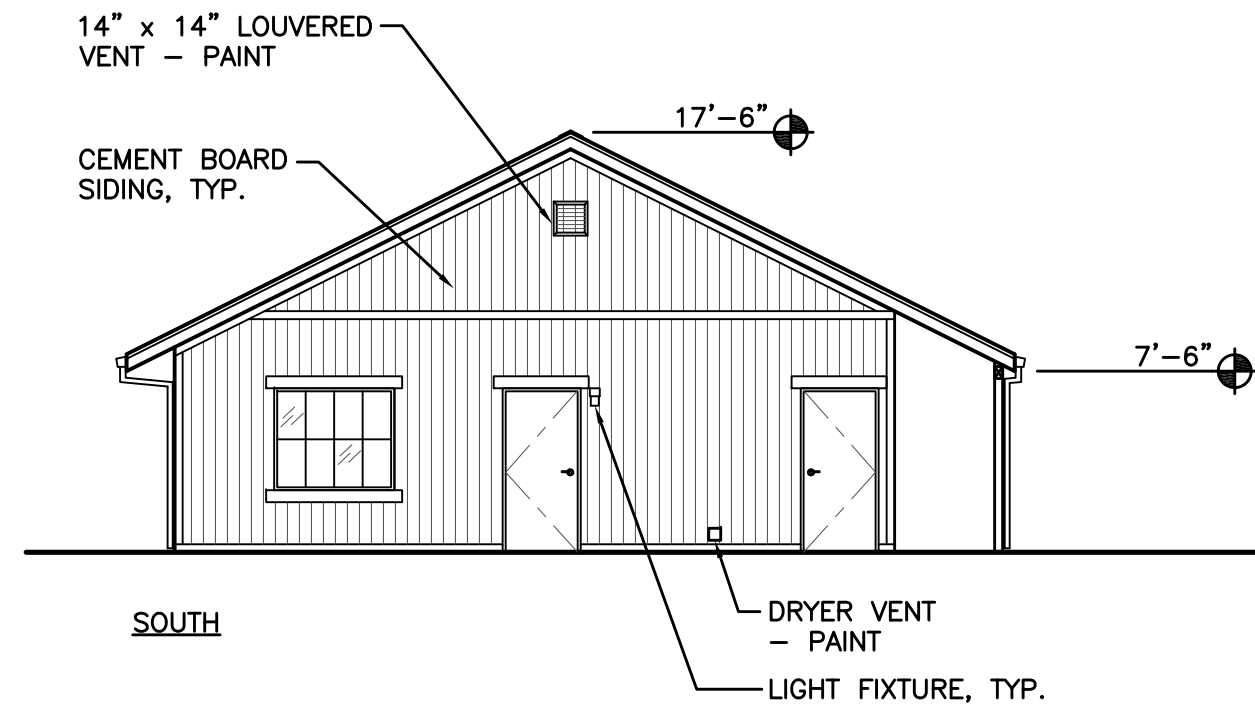

SOUTH

DRYER VENT
- PAINT

LIGHT FIXTURE, TYP.

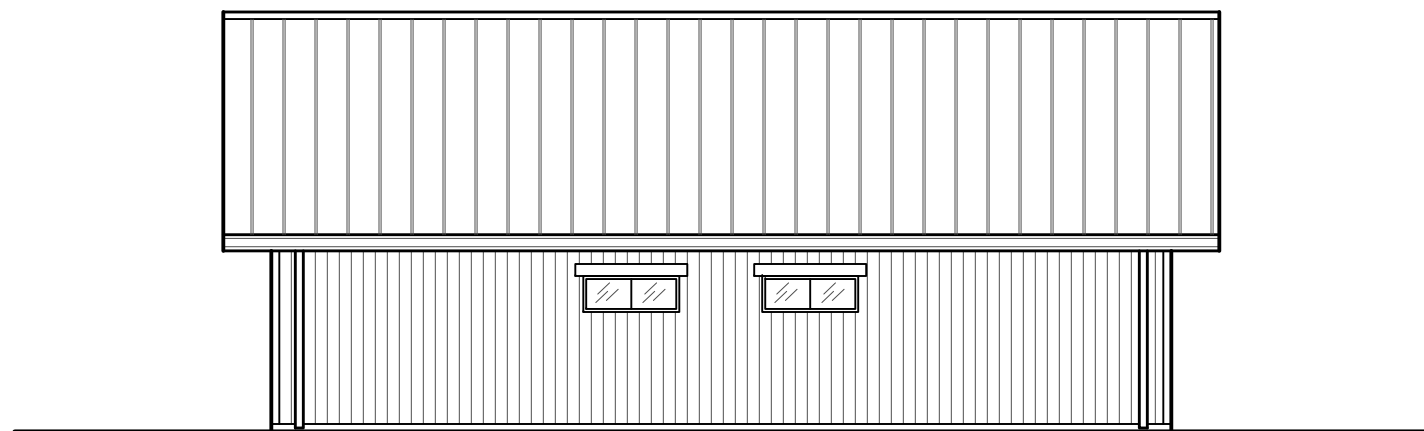

WEST



NORTH

1
A-2.1

EXTERIOR ELEVATION - RESIDENCE

FILE: HVESS_XEL_HOUSE

SCALE: 1/8"=1'-0"

REVISIONS

NO.	DESCRIPTION	DATE

DRAWN BY: MD CHK. BY: KD

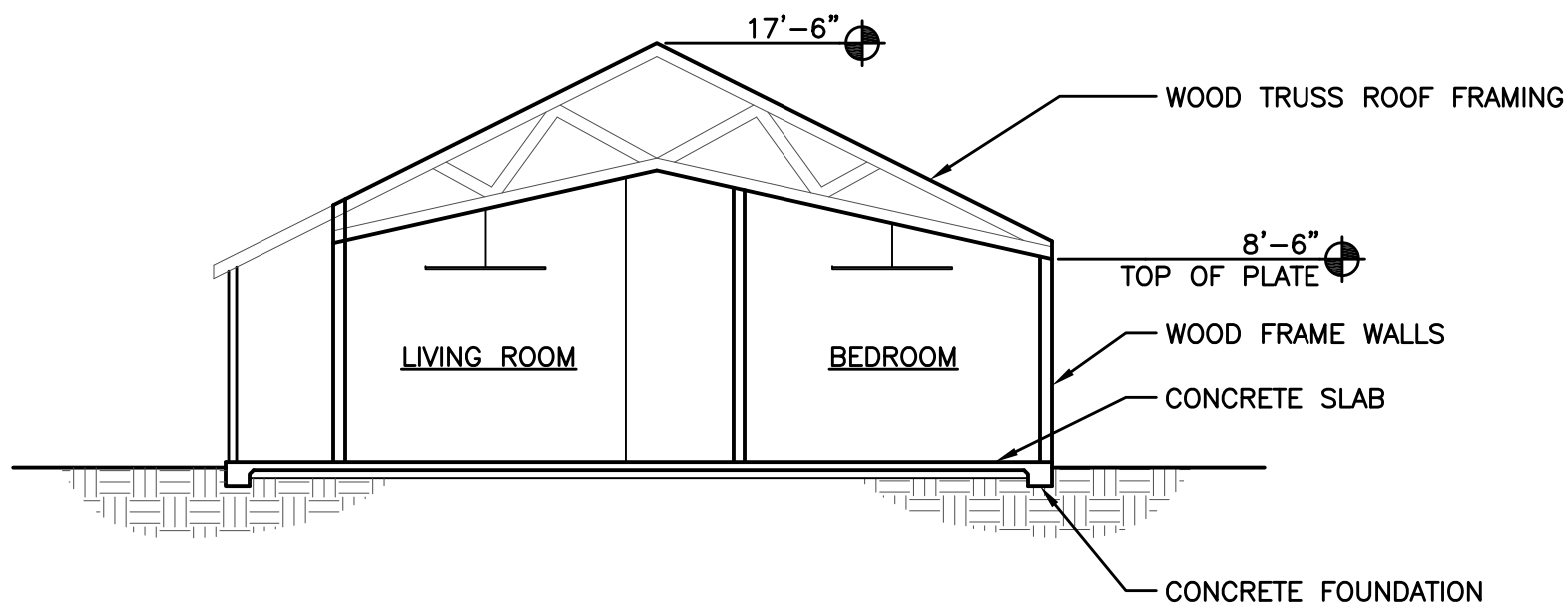

HAMMIL VALLEY
EMERGENCY
SERVICES STATION
HIGHWAY 6
DRAFT

ALL DRAWINGS AND WRITTEN MATERIAL
APPEARING HEREIN CONSTITUTE ORIGINAL
AND UNPUBLISHED WORK OF HMR ARCHITECTS
AND MAY NOT BE DUPLICATED, USED OR
DISCLOSED WITHOUT WRITTEN CONSENT
OF HMR ARCHITECTS.

10049

JUNE 30, 2011

A-2.2

13 OF 17

1 SECTION
A-2.2

FILE: HVESS_SEC

SCALE: 1/8"=1'-0"

REVISIONS

NO.	DESCRIPTION	DATE

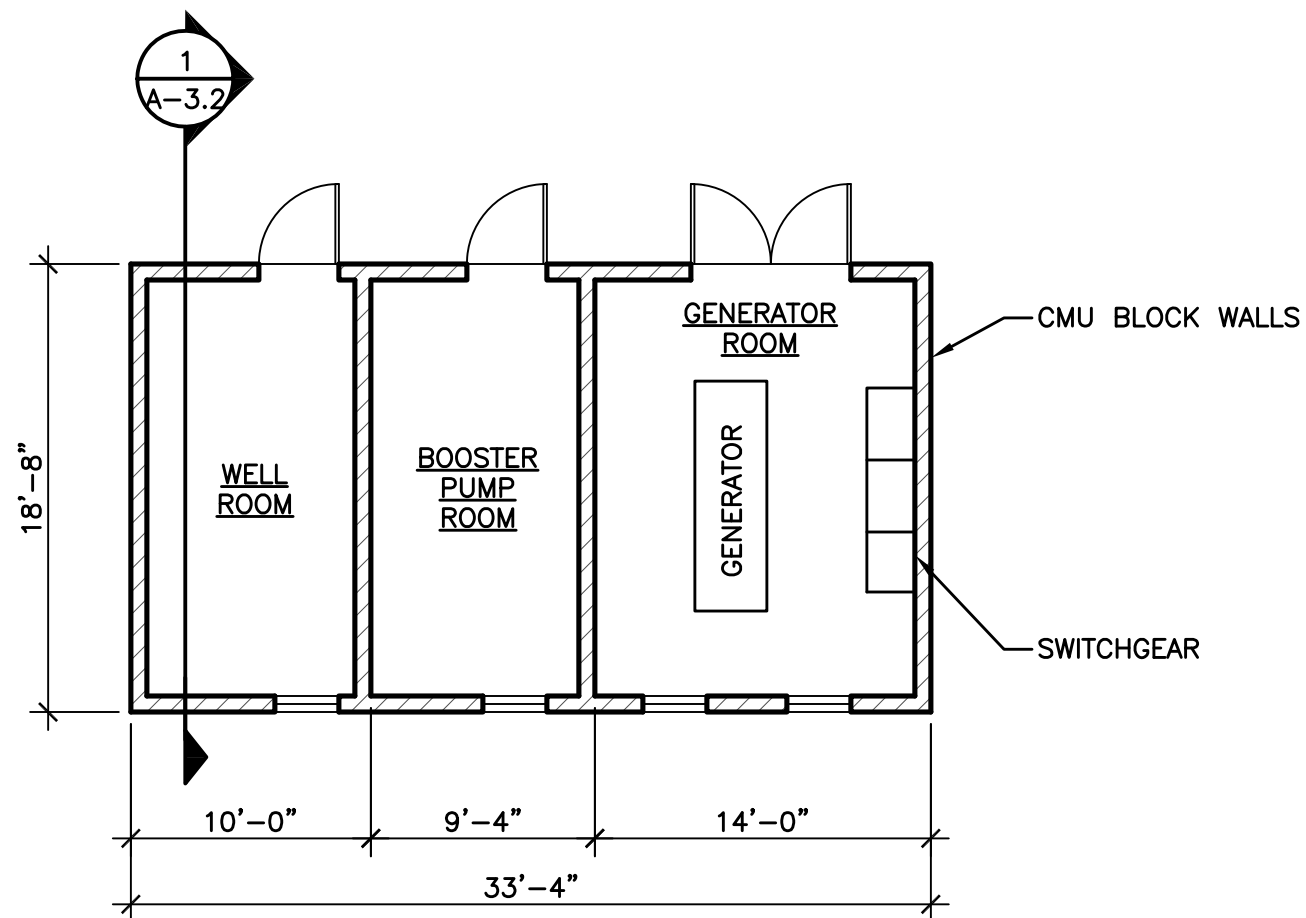

DRAWN BY: MD CHK. BY: KD

HAMMIL VALLEY
EMERGENCY
SERVICES STATION
HIGHWAY 6
DRAFT

ALL DRAWINGS AND WRITTEN MATERIAL
APPEARING HEREIN CONSTITUTE ORIGINAL
AND UNPUBLISHED WORK OF HMR ARCHITECTS
AND MAY NOT BE DUPLICATED, USED OR
DISCLOSED WITHOUT WRITTEN CONSENT
OF HMR ARCHITECTS.



NORTH

10049

JUNE 30, 2011

A-3.0

15 OF 17

1
A-3.0

FLOOR PLAN - PUMP/WELL/GENERATOR BUILDING

FILE: HVESS_FLR_GEN_1_P

SCALE: 1/8"=1'-0"

REVISIONS

NO.	DESCRIPTION	DATE

DRAWN BY: MD CHK. BY: KD

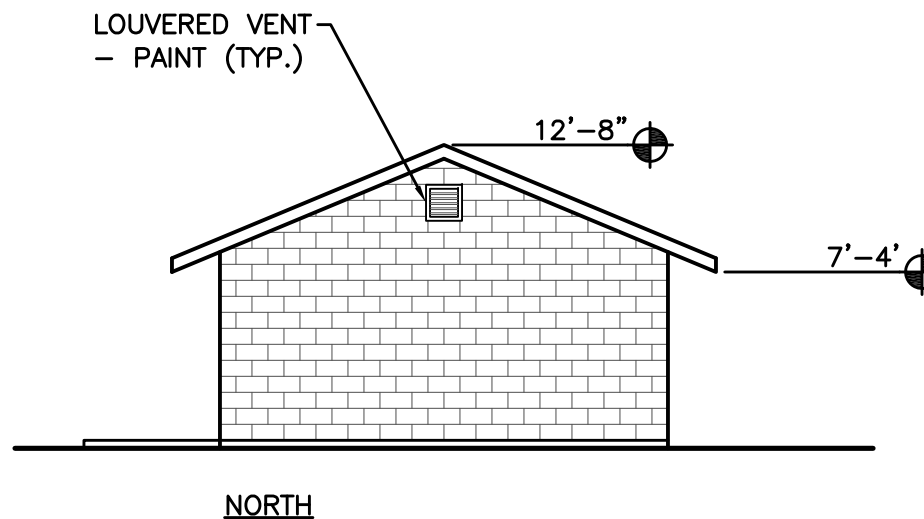
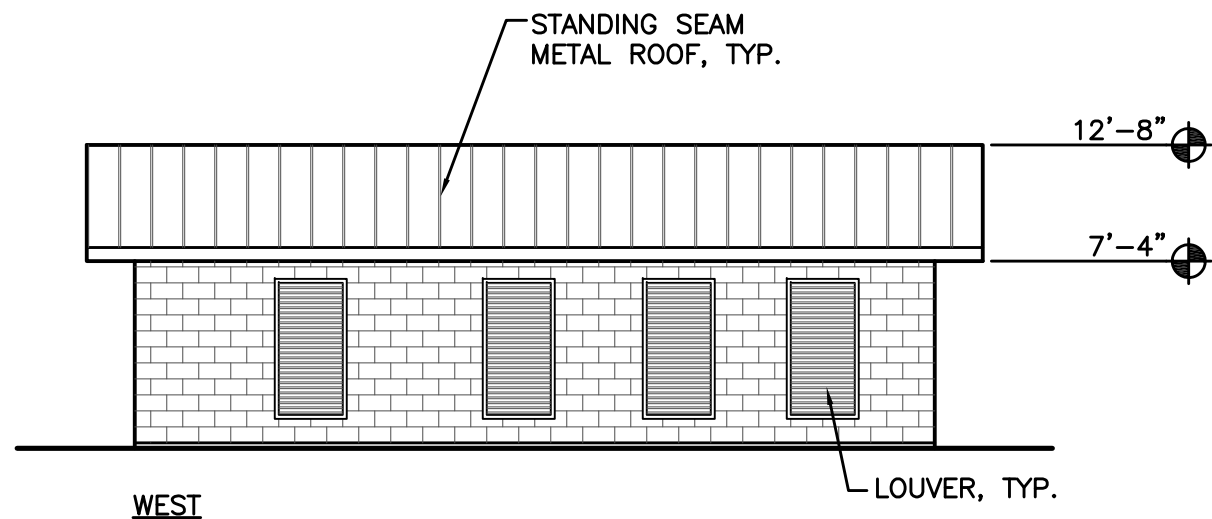
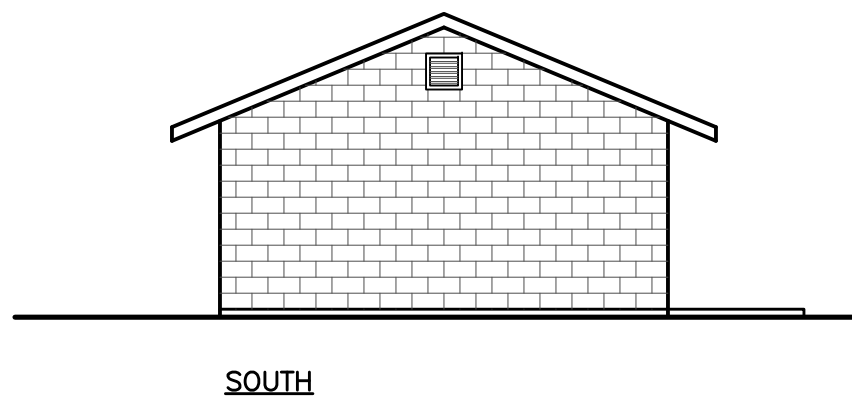
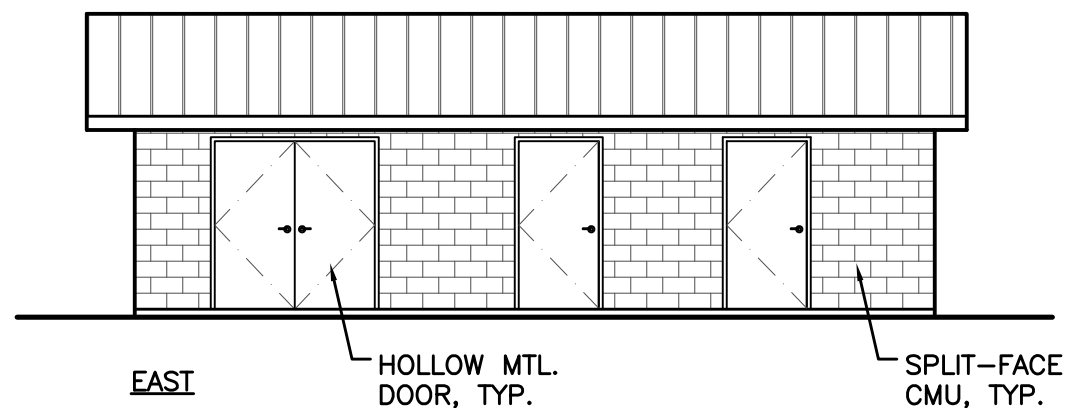

HAMMIL VALLEY
EMERGENCY
SERVICES STATION
HIGHWAY 6
DRAFT

ALL DRAWINGS AND WRITTEN MATERIAL APPEARING HEREIN CONSTITUTE ORIGINAL AND UNPUBLISHED WORK OF HMR ARCHITECTS AND MAY NOT BE DUPLICATED, USED OR DISCLOSED WITHOUT WRITTEN CONSENT OF HMR ARCHITECTS.

10049

JUNE 30, 2011

A-3.1

16 OF 17

1 EXTERIOR ELEVATION - PUMP/WELL/GENERATOR BUILDING

A-3.1 FILE: HVESS_XEL_GEN

SCALE: 1/8"=1'-0"

REVISIONS

NO.	DESCRIPTION	DATE

DRAWN BY: MD CHK. BY: KD

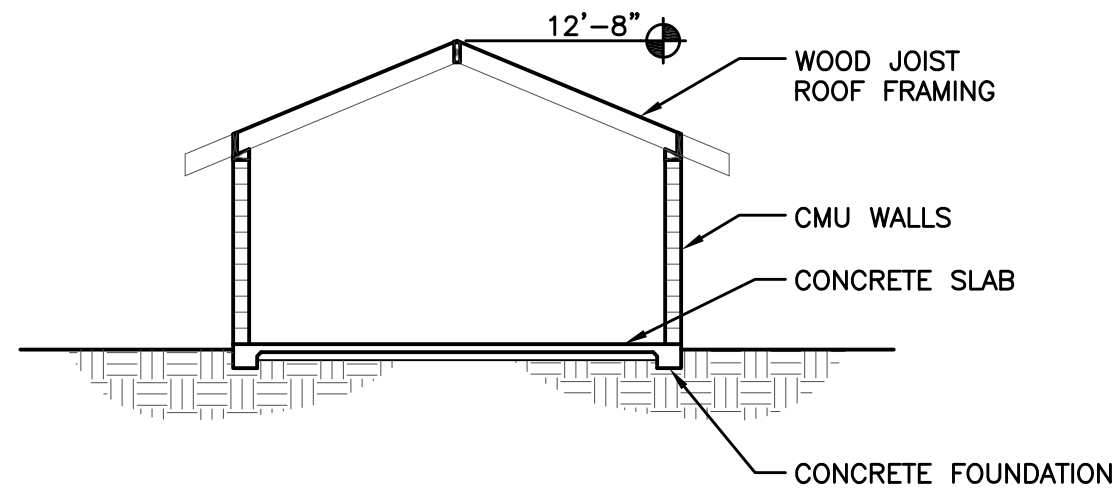

HAMMIL VALLEY
EMERGENCY
SERVICES STATION
HIGHWAY 6
DRAFT

ALL DRAWINGS AND WRITTEN MATERIAL
APPEARING HEREIN CONSTITUTE ORIGINAL
AND UNPUBLISHED WORK OF HMR ARCHITECTS
AND MAY NOT BE DUPLICATED, USED OR
DISCLOSED WITHOUT WRITTEN CONSENT
OF HMR ARCHITECTS.

10049

JUNE 30, 2011

A-3.2

17 OF 17

1
A-3.2

SECTION THRU PUMP/WELL/GENERATOR BUILDING

FILE: HVESS_SEC

SCALE: 1/8"=1'-0"